

SMF
Installation Manual

SMF430F-12X12UW

SMF520J-12X12UW

Contents

1.0 Summary.....	1
1.1 Disclaimer.....	1
1.2 Responsibility.....	1
1.3 Copyright and Trademark Information.....	2
1.4 Warranty Warnings.....	2
1.5 For Further Information.....	2
2.0 Safety precautions.....	3
3.0 Mechanical / electrical properties.....	5
4.0 Storage and unpacking.....	6
5.0 Installation.....	9
5.1 Module wiring.....	11
5.2 Grounding.....	12
6.0 Installation instructions.....	13
6.1 Module and tools.....	13
6.1.1 Module.....	13
6.1.2 Construction materials.....	13
6.2 Unpacking, Handling and Checking Precautions.....	14
6.3 Construction Precautions.....	15
6.4 Precautions and Tips for Gluing Modules.....	16
6.5 Trapezoidal Metal Roof Construction Plan.....	17
6.5.1 Supporting material.....	17
6.5.2 Cleaning the roof surface.....	17
6.5.3 Positioning and releasing the line.....	18
6.5.4 Gluing.....	19
6.5.5 Laying modules.....	22
6.6 Standing Seam Metal Roof Construction Plan.....	25
6.6.1 Supporting material.....	25

6.6.2	Cleaning the roof surface	25
6.6.3	Positioning and releasing the line	26
6.6.4	Gluing	27
6.6.5	Laying modules.....	30
6.7	Flat Roof Aluminum Tube Construction Plan	33
6.7.1	Supporting material.....	33
6.7.2	Cleaning the roof surface	33
6.7.3	Positioning	34
6.7.4	Apply primer (ignore this step if no primer required for the roof material)	34
6.7.5	Apply activator for PVC tube (ignore this step for the aluminum tube)	35
6.7.6	Paste tube	35
6.7.7	Laying modules.....	37
6.7.8	Joint of tubes	43
6.8	Clamps and Rails Construction Plan.....	Error! Bookmark not defined.
6.8.1	Supporting material.....	Error! Bookmark not defined.
6.8.2	Positioning and releasing the line	Error! Bookmark not defined.
6.8.3	Install the clamp.....	Error! Bookmark not defined.
6.8.4	Install the rail	Error! Bookmark not defined.
6.8.5	Specific Details of Rail Installation	Error! Bookmark not defined.
6.8.6	Apply the Glue	Error! Bookmark not defined.
6.8.7	Laying Modules	Error! Bookmark not defined.
6.8.8	The Width of the Central Aisle	Error! Bookmark not defined.
6.8.9	Precautions for Installing Adjacent Rails	Error! Bookmark not defined.
6.9	Wiring and testing	45
7.0	Maintenance	47
Annex A	48

Electrical performance parameter	48
Annex B	49
Cleaning agent	49
Annex C	50
Gluing operation specification	50
1. Gluing nozzle cutting	50
2. Electric glue gun adjustment	51
3. Gluing parameters	52
4. Structural adhesive form	53
Annex D	54
Unpacking	54

1.0 Summary

Thank you for purchasing SunMan PV modules. This guide contains information regarding the installation and safe handling of SunMan (Zhenjiang) Company Limited PV system on Roofs. SunMan (Zhenjiang) Company Limited referred to as “SUNMAN”. Users and installers have the responsibility to read and understand the installation methodology. Users and installers must complete their own specific site engineering review to ensure the proposed methodology is fit for purpose. Failure to follow these safety guidelines can result in personal injury or property damage. The installation and operation of solar modules require specialized skills, and only professionals can do the job. Please read the safety and installation instructions before using and operating the modules. The installer and distributor must inform the end customer (or consumer) of the above matters accordingly.

1.1 Disclaimer

SunMan reserves the right to change this installation manual without prior notice. The changes and the latest installation manuals after the changes will be published in the resource center of the official SunMan website. Customers should always pay attention to the above changes. SunMan will not provide further notice.

Failure in operating according to instructions in this manual during installation (Including the changes announced on the official website of SunMan at the time of installation) will cause the warranty to be invalid.

SunMan does not guarantee any expressed or implied information contained in this manual. Users and installers must complete their own specific site engineering review to ensure the proposed methodology complies with local laws and construction standards.

1.2 Responsibility

Whether or not the installation of the modules is carried out in accordance with the instructions in the installation manual (Including the changes announced on the official website of SunMan at the time of installation), SunMan shall not be held legally responsible for any damages incurred during the installation process, including but not limited to personal and property damage resulting from the operation of the modules and the installation of the system.

This manual is for installation guidance only and does not constitute any form of warranty, whether explicitly stated or implied.



1.3 Copyright and Trademark Information

Copyright © 2024 by SunMan (Zhenjiang) Company Limited. All rights reserved. The SUNMAN logo are trademarks of SunMan (Zhenjiang) Company Limited.

1.4 Warranty Warnings

WARRANTY VOID IF NON-SUNMAN-CERTIFIED HARDWARE IS ATTACHED TO SUNMAN PV MODULE.

1.5 For Further Information

For additional technical support documentation, please visit the Support page of the SUNMAN website at 'www.sunman-energy.com'.

2.0 Safety precautions



WARNING: Prior to the installation, wiring, operation, or maintenance of the modules, it is imperative to thoroughly read and comprehend all safety instructions. Failure to adhere to these instructions may result in property damage or pose serious risks, including injury or death. DC power is generated when the module is exposed to sunlight or other light sources. Direct contact with live parts of the module, such as terminals, whether connected or not, may result in personal injury or death.

Safety rules

- All installation work must be in full compliance with local regulations and corresponding national or international electrical standards.
- Use insulated tools to reduce the risk of electric shock.
- Use appropriate protective measures (slip gloves, overalls, etc.) to avoid direct contact with workers at 30V DC or higher, while avoiding direct contact with sharp edges during installation to protect the operator's hands.
- Do not wear metal ornaments when installing, to avoid puncturing the modules and causing electric shock.
- If modules are installed or operated on rainy days, strong winds or dew mornings, appropriate protective measures should be taken to avoid injury to modules and workers.
- When working in rooftop applications, it is imperative not to engage in any activities on the roof without proper safety precautions. Such precautions include, but are not limited to, fall protection measures, the use of ladders or stairs, and the utilization of personal protective equipment.
- Children or unauthorized personnel are not allowed to access the installation area or module storage area.
- If the circuit breaker and overcurrent protection circuit breaker cannot be opened, or if the inverter cannot be turned off during the module installation or wiring, cover the array modules with opaque material to stop the power output.
- Do not use or install damaged modules.
- If the module surface is damaged or worn, direct contact with the surface of the module may result in electric shock.

- Do not attempt to repair any part of the module, there are no user-accessible components within the module.
- The cover of the junction box shall remain closed at all times.
- Do not split the modules or alter any part of the module.
- Do not artificially condense light on modules.
- Do not connect or disconnect modules when there is current in the module or external current.

3.0 Mechanical / electrical properties

The rated electrical performance data for the modules is measured under standard test conditions (STC) of irradiance of 1000 W/m², AM 1.5, and cell temperature of 25 °C. The specific electrical and mechanical performance parameters of SunMan modules are included in Annex A of this installation manual. The main electrical performance parameters under STC conditions are also marked on the nameplate of each module. The maximum system voltage for all modules is 1500V.

In some cases, the current or voltage generated by the module may be greater than the optimal operating current or voltage of its standard test condition (STC). Therefore, when determining the component rating and load value, the module open circuit voltage and short circuit current at STC should be multiplied by 1.25. Please check with your local rules and regulations.

4.0 Storage and unpacking

Precautions and general safety rules

- Store modules in a dry and ventilated environment.
- The modules must be transported in the package provided by SunMan and stored in the original package before installation. Please protect the packaging from damage. Open the package according to the recommended unpacking steps. Care must be taken during unpacking, shipping, and storage.
- Do not apply excessive loads on the modules or twist the modules.
- Do not carry the modules by the wires or junction boxes of the modules.



- Do not stand, climb, walk or jump on modules.







- Do not allow sharp objects to touch the modules. Scratches can directly affect the safety of the modules.
- Do not leave the modules unsupported or unsecured.
- Do not change the wiring method of the bypass diode.
- Keep all electrical connections clean and dry.

Product identification

- Barcode: each individual module has a unique serial number. The serial number has 21 digits. The 1st to 4th digits are the module type for internal use, and 5th to 8th digits are the year code, and the 9th and 10th digits are the month code, and the 11th and the 12th digits are the week code, and the 13th and 14th digits are the month code, and the 15th to 17th digits are order number, and the 18th to 21th digits are the sequence codes. For example, xxxx20210415xxxxxxxxx means the module was made in the 15th week of 2021. Each module has only one bar code. It is permanently attached to the interior of module and is visible from the top front of module. This bar code is inserted prior to lamination.



- There is a nameplate, which shows the model number, main electrical properties, safety specifications and certification indicator, on the back of each module.

SUNMAN		Model Number: SMF520J-12X12UW	Cell Technology: mono-Si
Model (T98)max(°C): :70	Design Load(Pa,safety factor excluded) :+3600/-1600	Power Binning: 0 ~ +5W	Maximum System Voltage: 1500V
Connector(See manual for further instructions) :Stäubli MC4-EVO2		Rated Maximum Power (P _{max}) :520W ±5%	Maximum Series Fuse Rating: 25A
		Current at P _{max} (I _{mp}) :12.31A	Application: Class II
		Voltage at P _{max} (V _{mp}) :42.26V	Weight: 7.2kg
		Short-Circuit Current (I _{sc}) :13.56A ±5%	Dimension: 2246×1197×2mm
		Open-Circuit Voltage (V _{oc}) :49.54V ±5%	
All technical data at standard test condition AM=1.5 E=1000W/m ² T _c =25°C IEC 61215-1/-1-1/-2:2021 IEC 61730-1/-2:2023			
WARNING Hazardous electricity can shock, burn or cause death. Do not touch terminals.			
Sunman (ZhenJiang) Co., Ltd. No.1.South Mingzhu Road,Youfang Town,Yangzhong,Zhenjiang,Jiangsu,P.R.China Customer Service Hot Line: 400 969 2800 Fax: +86 21 3988 1933		MADE IN CHINA	

5.0 Installation

Precautions and general safety rules

- Before installing the modules, please complete a specific site engineering review to ensure the proposed methodology complies with local laws, regulations and or constructions standards.
- Check the applicable building codes to ensure that the building is suitable for SunMan installation.
- During installation, make sure that the modules are installed on a fire-resistant roof. According to UL790 standards, SunMan modules are rated as fire rating C.
- The modules are compliant with application level A (equivalent to safety level II, IEC 61730-1). This type of modules can be used in systems where the public is likely to come into contact with voltages greater than 50V or power greater than 240W.

Environmental conditions

The modules are suitable for general climatic conditions, ie with reference to IEC 60721-2-1- Classification of environmental conditions Part 2-1: Environmental conditions occurring in nature - temperature and humidity.

- If the modules are used in a special installation environment, please consult the technical support department of SunMan in advance.
- The installation surface should be flat without bumps or pits.
- The modules must not be installed near flames or flammable objects.
- Do not expose modules to artificial condensing light sources
- The modules should not be immersed in water (pure water or salt water), installed in long-term water environment (pure water or salt water) (eg fountains, sprays, etc.) or area prone to water accumulation (eg roof drain, low-lying areas, etc.).
- If the module is placed in a salt mist (ie marine environment) or in an environment containing sulfur (ie, sulfur sources, volcanoes, etc.), there is a risk of corrosion.
- **Failure to follow the above precautions, SunMan Warranty will be voided.**

Installation requirements

- Ensure the modules meet the overall technical requirements of the system.

- Ensure that components of other systems do not cause damaging mechanical or electrical performance effects on the modules.
- Connect modules in series to increase voltage or in parallel to increase current. When connected in series, the positive pole of the module is connected to the next negative pole. When connected in parallel, the positive pole of the module is connected to the positive pole of the next module.
- The number of bypass diodes provided varies depending on the module model.
- Connect the appropriate number of modules according to the voltage specifications of the inverter used in the system. Even at the lowest local temperature conditions, the connected modules must produce no more than the voltage allowed by the system. If overcurrent protection devices (fuse) are not used in series within each string of modules, up to two strings of modules can be connected in parallel. If a suitable overcurrent protection device is connected in series with each string of modules, three strings or more modules can be connected in parallel.
- In order to avoid (or reduce) the mismatch effect of the array, it is recommended to connect modules of similar electrical performance on the same string.
- In order to reduce the risk of indirect lightning strikes, loops should be avoided when designing the system.
- The modules should be securely fixed to withstand all possible loads, including wind and snow loads.
- When installing modules for rooftop applications, it is crucial to consider long-term maintenance. Roofs designated for PV system installation must undergo assessment by construction experts or engineers. Formal and thorough structural analysis results must be obtained in accordance with local requirements, including verifying the roof's capacity to withstand additional loads from the system supports and the weight of the modules.
- Movement of the substrate should be taking into consideration when planning the panel layout. Example areas of installation which may cause damage include but are not limited to: different sections of rail and ends of roof sheets.
- **Non-compliance with the installation specifications outlined in this manual may lead to damages such as microcracks in modules or potential fire hazards.**

Optimal orientation and inclination

- In order to achieve maximum annual power generation, the optimal orientation and inclination of the PV module should be determined first. The maximum amount of power is typically generated when the sun is directly above the PV module.
- In the Southern Hemisphere, the modules should generally face north to attain the maximum energy yield.
- The module is required to be mounted at a minimum inclination of 5 degrees. In the event that the mounting angle is excessively small, there may be a significant accumulation of dust and water on the surface of the module.

Avoid shadows

- Even small shadows (such as dust) can cause a drop in power generation. If all surfaces of the module are uncovered throughout the year, the module is considered "no shadow". Ensure that the sun shines on the modules even on the shortest day of radiation all through the year.
- EVA aging caused by frequent occlusion of modules and long-term heating of the diode can affect the lifetime of the module.

5.1 Module wiring

Correct electrical wiring

- Check that the wiring is correct before starting the system. If the measured open circuit voltage (Voc) and short circuit current (Isc) do not match the specifications provided, there may be a wiring fault.

Correct connection of the MC4 connector

- Make sure the MC4 connector is secure and properly connected. The tightening torque must be appropriate for the solar cables used. Typical values are between 3.4 Nm and 3.5 Nm (refer to the connector supplier information for specific connection steps). The connector should not be subjected to external pressure. It is solely intended for electrical circuit connections and should not be used to open or close circuits. Do not insert other metal objects into the connector or attempt any other electrical connections.
- The MC4 connector should be kept dry and clean to prevent rain and moisture. Avoid water soaking of the MC4 connector.
- The junction box and the connector shall not be in contact with organic solvents, oily substances and other corrosive materials that may cause

functional failure, to avoid damage to the junction box and the connector. If the junction box and connector are contaminated, they are forbidden to use.

Use appropriate materials

- In accordance with local fire, building, and electrical regulations, it is essential to use specialized solar cables and connectors of the same brand and model as those used by SunMan. Additionally, ensure that the electrical and mechanical performance of the cables is excellent.
- The solar cable licensed for use is a single-wire cable, 4-10mm² (8-11 AWG), 90°C grade, with appropriate insulation to withstand the maximum possible system open circuit voltage. The appropriate wire size needs to be chosen to reduce the voltage drop. The wire should be made of copper.

Cable protection

- Secure the cable with a cable tie that is UV resistant. Appropriate measures should be taken to protect the exposed cable from damage (eg. in a conduit with UV aging resistance).

5.2 Grounding

- The module does not involve any metallic conductor for the module, so there should not be a need to set up a grounding system for the panel. Please reference to local standards.

6.0 Installation instructions

6.1 Module and tools

6.1.1 Module

Applicable module model: SMF430F-12X12UW, SMF520J-12X12UW

The electrical performance parameters are detailed in Annex A.

6.1.2 Construction materials

Silicone sealant (glue), cleaning tool, tape measure, thread release tool, etc.

- **Silicone sealant (glue)**



- **Glue gun**



- **Cleaning tool**

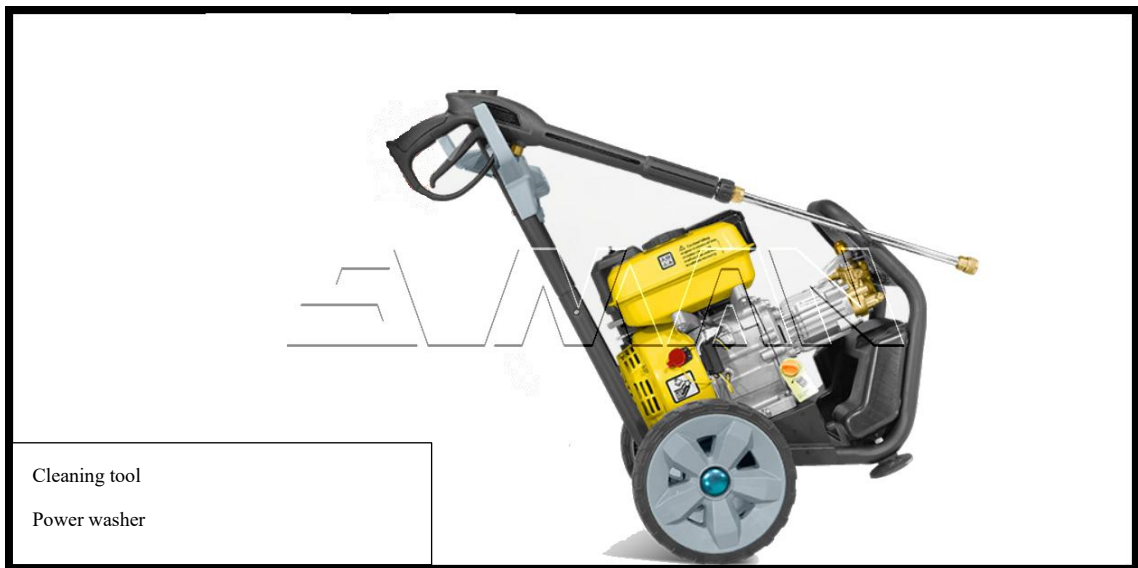

6.2 Unpacking, Handling and Checking Precautions

- Do not open modules outer Package before installation.
- Check the outer package for damage before unpacking.
- Slip-Proof Gloves are recommended for unpacking and handling.
- Do not grab the modules by the junction box or cables during unpacking or handling.
- Modules should be handled and lifted by at least two people. Do not touch the solar cell area during handling to avoid cell-cracks.

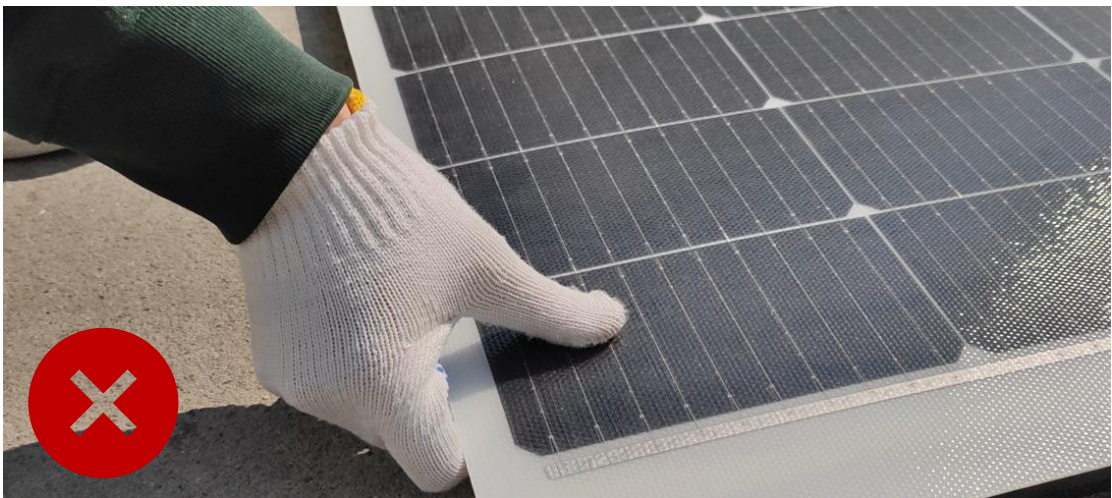

- Be careful while carrying the modules. Avoid hitting the modules on the

ground or other sharp, hard objects.

- Check the surfaces of the modules, make sure there is no damage to the frontsheet and the backsheet.
- Check the junction box, connectors, and cables for any damage. Double check if the junction box cover is fixed securely.
- Do not paint or apply glue or label on the surface of the modules.

6.3 Construction Precautions

- Before commencing construction, please ensure you have read the adhesive manufacturer's manual to ensure that all the adhesive application requirements are followed. The construction can proceed normally within a temperature range of 5 to 40°C and a humidity level below 80% (The specific construction temperature range should be based on the information provided by the adhesive manufacturer).
- The surface of the roof must be cleaned or wiped dry, free of floating soil, oil, etc. In order to achieve the required adhesion, the roof shall be cleaned using the cleaning agent specified in Annex B or SunMan- approved cleaning agent. Please refer to adhesive manufacturer's substrate preparation.
- After initial installation, the panel and adhesion shall not be disturbed for a minimum of 24 hours. Please refer to adhesive manufacturer's guidelines.
- The roof angle is within 45 degrees. Please refer to adhesive manufacturer's guidelines. If slippage occurs, appropriate measures must be taken.
- The paste surface needs to be flat and free of pits or bumps.
- When storing installation material used in installation, it should comply with the storage specifications for installation material.
- Ensure substrate(s) have been tested and paired to compatible adhesives or bonding procedure. If unsure, please seek clarification from the adhesive manufacturer or SunMan.
- The bonding lines to substructures and the roof must be parallel to the short side of the module. It is prohibited for the bonding lines to be parallel to the long side of the module regardless of number.

6.4 Precautions and Tips for Gluing Modules

- Before commencing construction, please ensure you've read the adhesive manufacturer's manual to ensure that all the adhesive application requirements are followed. Please make sure the surface is cleaned and there are no water pits before gluing;
- After applying the adhesive, the width shall be no less than 10mm and the height no less than 5mm. After bonding, the height of the structural adhesive should be between 3-10mm. It should not be too high or too flat; if too high, the curing time of the structural adhesive will be excessively long; if too flat, the adhesive bond will fail. Do not use foot or any non-designated tools to press down the adhesive. The exact requirements should be referred to those mentioned in the structural assessment and in the adhesive manufacturer's requirements.
- The application of the adhesive should be a continuous and even movement preferable from a caulking gun, using the weight of the module itself to spread the adhesive.
- Make sure to complete the gluing and mounting over a duration that does not exceed 5 minutes;
- Silicone sealant will cure to a depth of 2-3mm in 48 hours. Do not apply any force, move the module, or perform any tests before the adhesive is fully cured.
- The application requires the use of Tonsan 1527, Sika Sikasil SG-20s or other adhesives approved by SunMan.

Special glue curing table at different ambient temperatures			
Ambient Temperature (Ta)	$-10 \leq Ta \leq 0$	$0 < Ta < 20$	$20 \leq Ta \leq 45$
Full Solidification Time (Day)	21	14	7
Standard solidification conditions: temperature (23 ±2) °C, humidity (50 ±5) % conditions can be completely solidified in 7 days			

Table 1. Special adhesive full curing time

(This table is provided solely as a reference for the curing time of Tonsan 1527 adhesive. The specific curing time is subject to the information of the glue manufacturer)

6.5 Trapezoidal Metal Roof Construction Plan

Installation Steps

6.5.1 Supporting material

- Aluminum tube

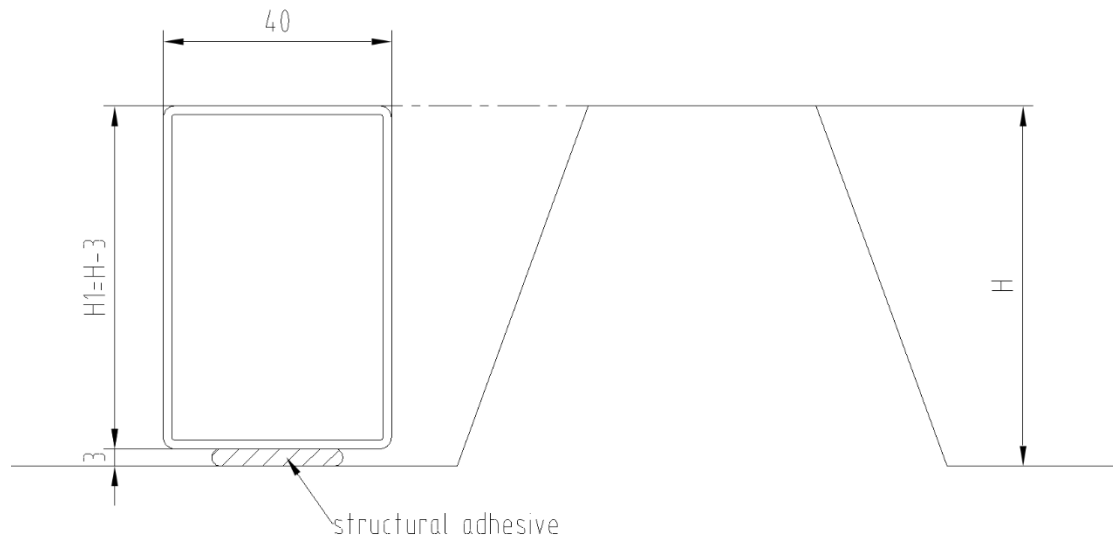

Material: Aluminum 6000 Series-T5/T6.

Surface treatment: Anodic oxidation AA10 and above

Dimensions: $B=40\text{mm}$, $H_1 = (H - 3\text{mm}) \pm 2\text{mm}$

6.5.2 Cleaning the roof surface

- Remove debris from the roof base and use a designated or approved cleaning agent (Annex B) to clean the roof. If the roof is very dirty, use a low-pressure water spray or power washer before using the cleaner. Optionally, use a mixture of 1/4 cup of trisodium phosphate, 1/2 cup of liquid cleaner and 5 gallons of water for cleaning.

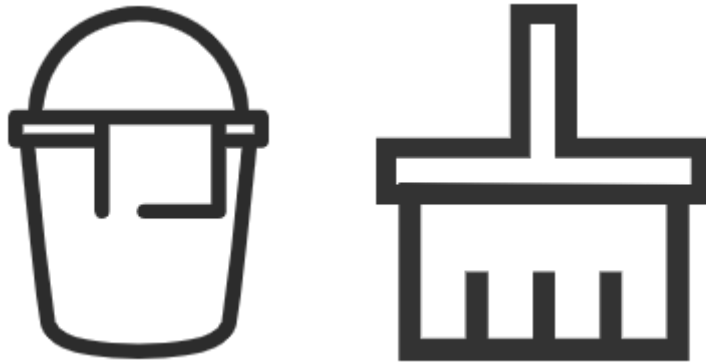

- Please refer to adhesive manufacturer's substrate preparation.

6.5.3 Positioning and releasing the line

- Locate the line and determine the installation position of the module.



- **Design consideration : Panels should not be placed where it will be subject to the roofs thermal expansion and contraction and other movement.**



6.5.4 Gluing

- The application of the adhesive on the roof sheet peak should be a continuous and even movement preferable from a caulking gun. Please refer to the adhesive manufacturer's installation manual.

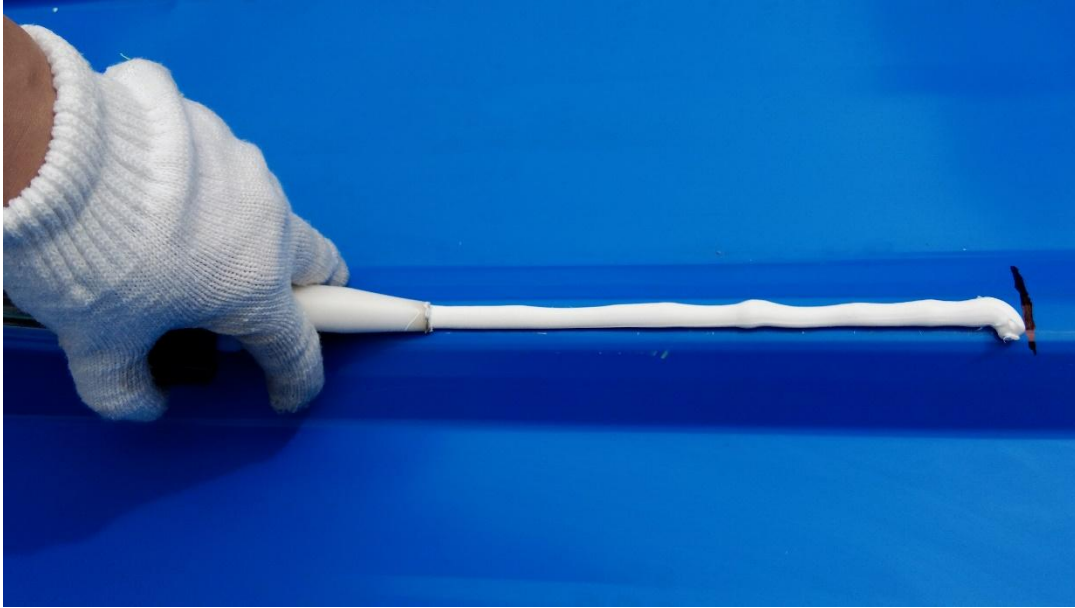

- The glue length L2 is the same at the width of PV panel, distance between glue L1 should be less than 520mm, If module hanging part is above 50mm, use aluminum tube.

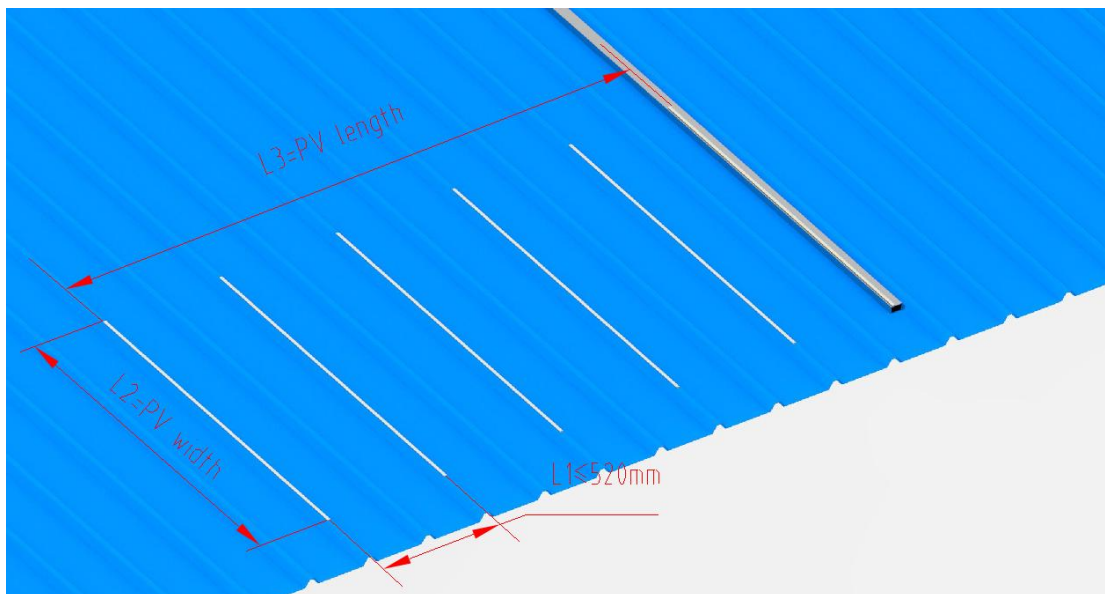

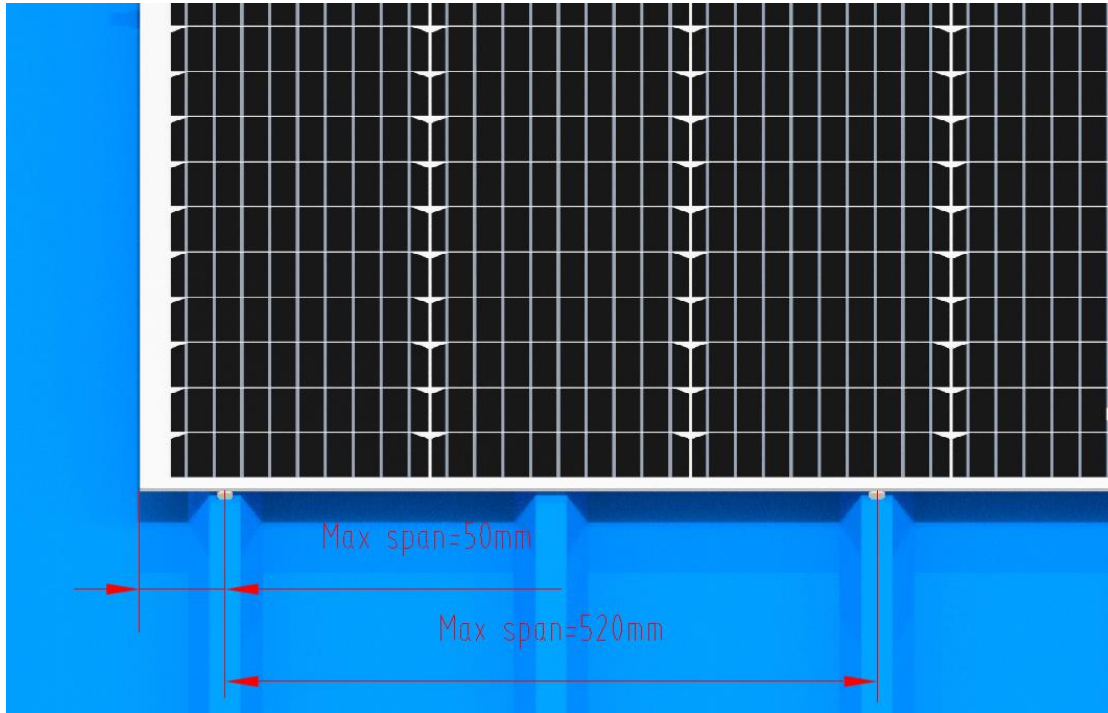

- If there are joints in the aluminum tube, they should be positioned between modules. Single module must not overlap the joints of the aluminum tube.

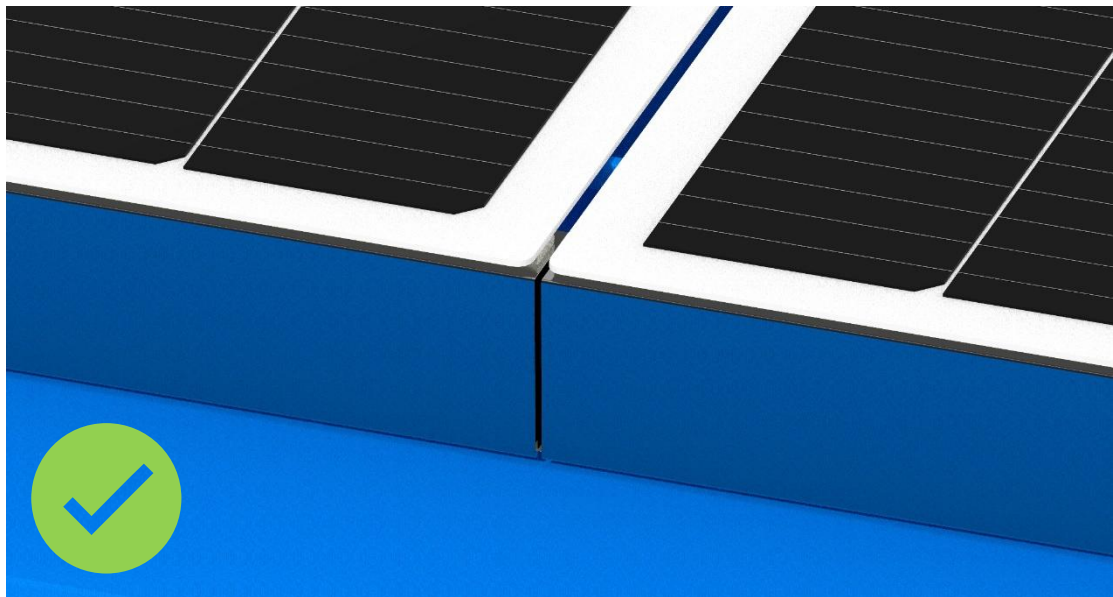

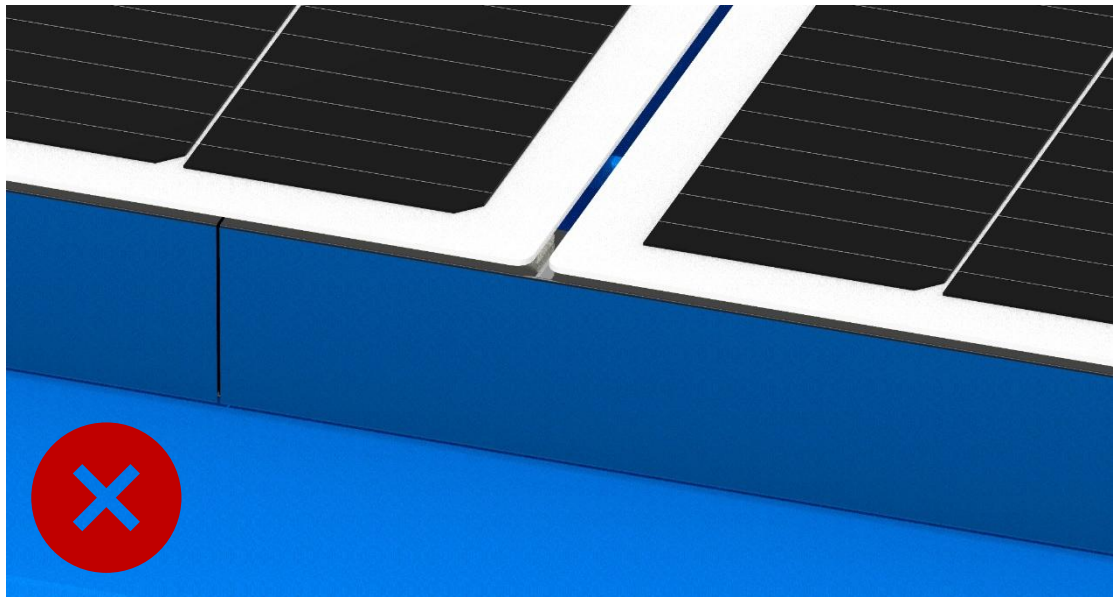

6.5.5 Laying modules

- Do not bend the module during installation. Two people should grasp the white edge of the module and place it onto the glue. Modules should be in a straight position during placement. Do not re-glue the modules.
- The short edges of the module must be parallel to the direction of the fall of the metal roof. It is prohibited to be perpendicular to the roof sheet peak of metal roof.
- Once modules are placed, avoid hand-pressing the cell-area to facilitate adhesion.
- The minimum distance between the modules is 5mm, and the distance between each array is 500-800mm, which is used as a construction maintenance walkway. (This spacing is for reference only)
- Adjacent modules can share the same Aluminum tube.
- Place the junction box on the maintenance walkway side for easy string wiring and maintenance inspection.
- Follow the steps above to install the other modules.

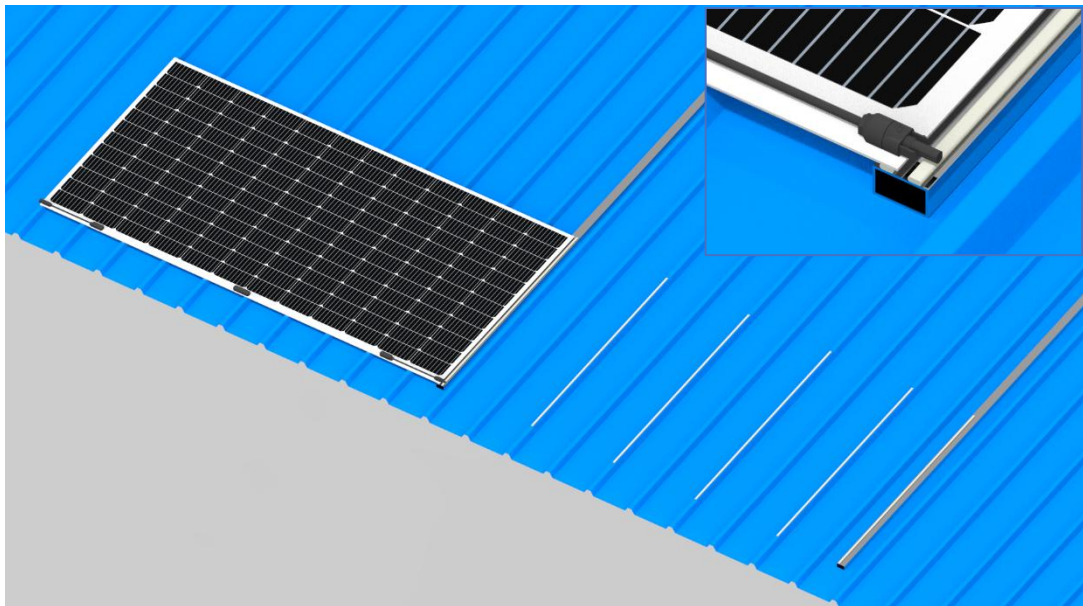
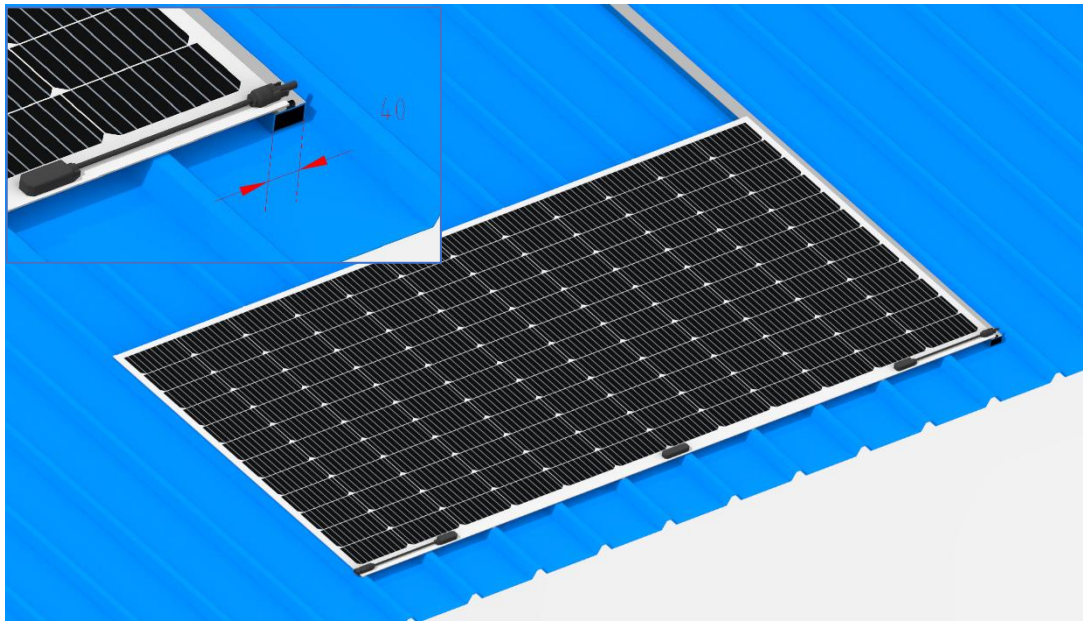

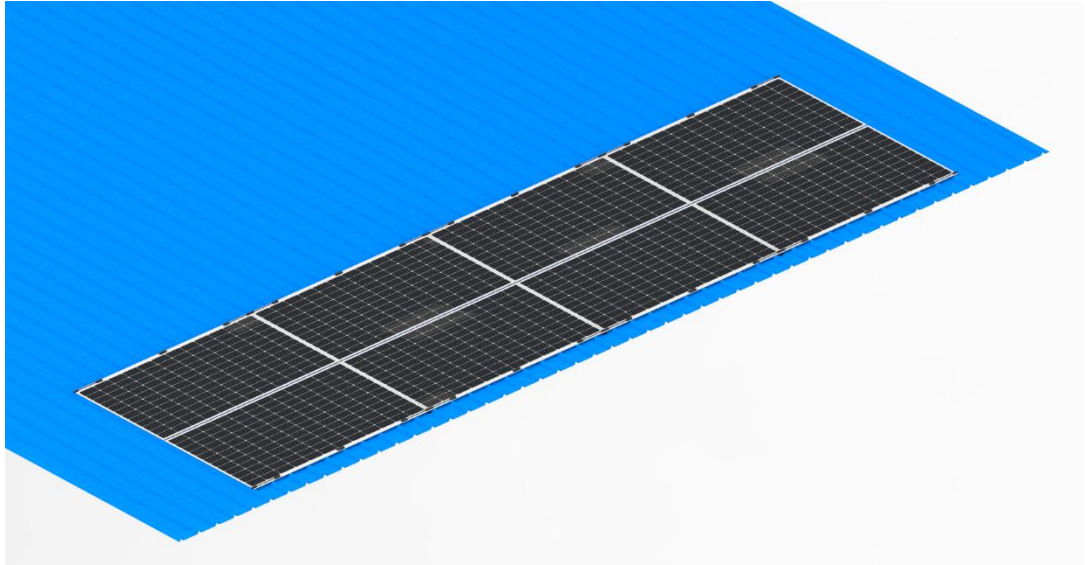

6.6 Standing Seam Metal Roof Construction Plan

Installation Steps

6.6.1 Supporting material

- Aluminum tube

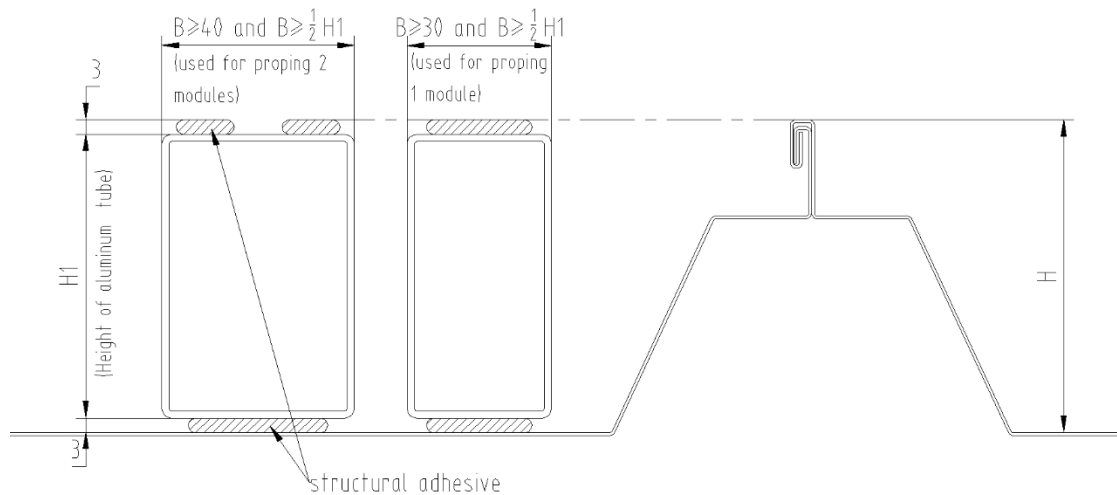

Material: Aluminum 6000 Series-T5/T6.

Surface treatment: Anodic oxidation AA10 and above

Dimensions: $H1 = (H - 6\text{mm}) \pm 2\text{mm}$

For the tube at the joint of two modules, $B = 40\text{mm}$, and $B \geq \frac{1}{2} H1$;

For other tube, $B \geq 30\text{mm}$, $B \geq \frac{1}{2} H1$.

6.6.2 Cleaning the roof surface

- Remove debris from the roof base and use a designated or approved cleaning agent (Annex B) to clean the roof. If the roof is very dirty, use a low-pressure water spray or power washer before using the cleaner. Optionally, use a mixture of 1/4 cup of trisodium phosphate, 1/2 cup of liquid cleaner and 5 gallons of water for cleaning.

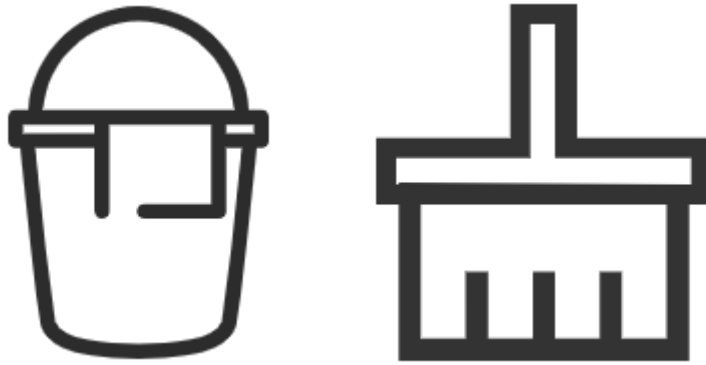

6.6.3 Positioning and releasing the line

- Locate the line and determine the installation position of the module.

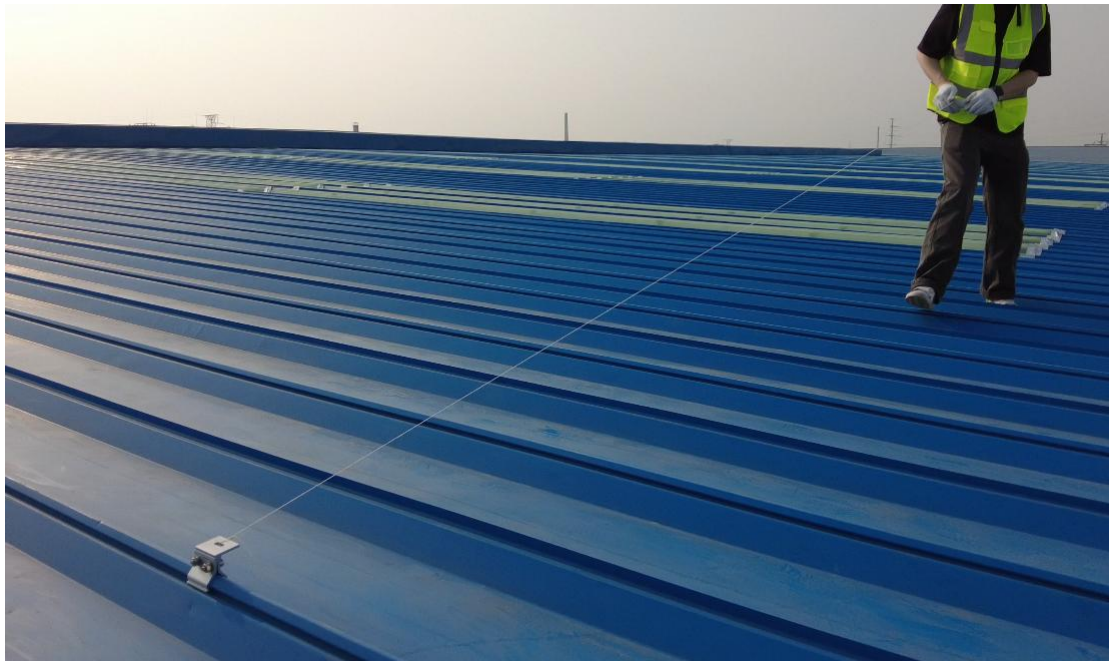

- For the SMF430F-12X12UW module, using at least five aluminum tubes to support, which are uniformly distributed in the length direction of the module.
- For the SMF520J-12X12UW module, using at least six aluminum tubes to support, which are uniformly distributed in the length direction of the module.
- When the position of the tube is interfered with the roof sheet peak, the position of the tube can be adjusted appropriately;
- **If there are joints present from the ridge of the corrugated metal roof to the eaves, the seams must be positioned between modules rather than**

being covered by one single module.



6.6.4 Gluing

- The application of the adhesive on the roof sheet valley should be a continuous and even movement preferable from a caulking gun. Please refer to the adhesive manufacturer's installation manual.
- Paste aluminum tube. Use the tube with width of 40mm at the joint of two modules, and use the tube with width ≥ 30 mm at other positions.
- The glue length L2 is the same at the width of PV panel, L3 is the length of PV panel.

- Glue evenly on the tube surface.

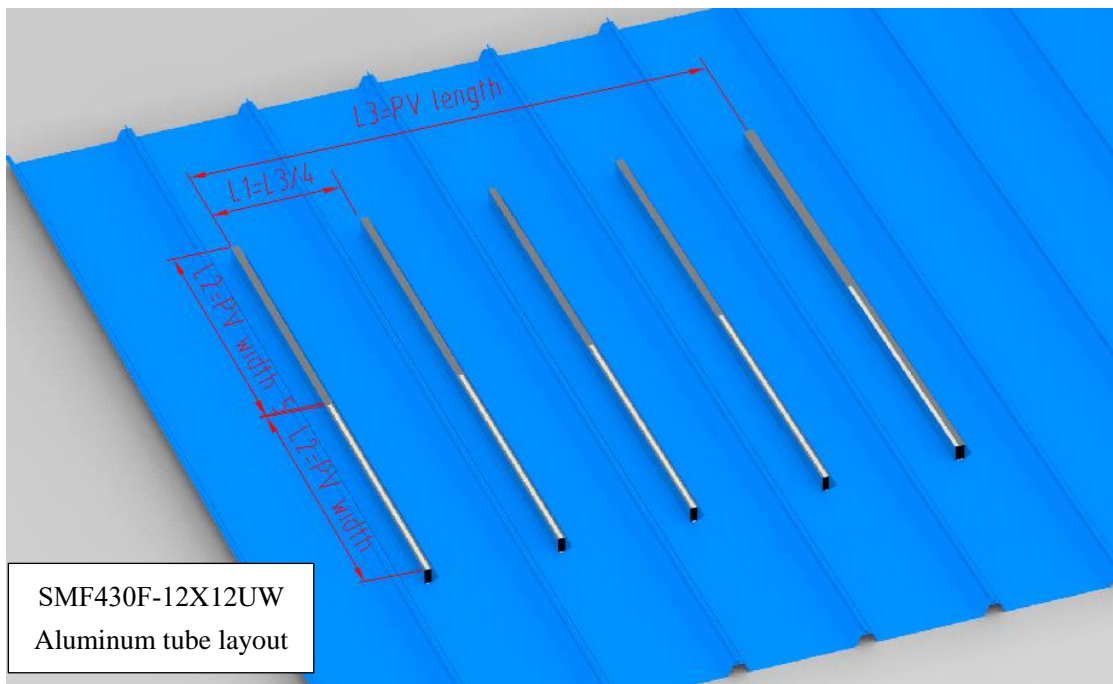
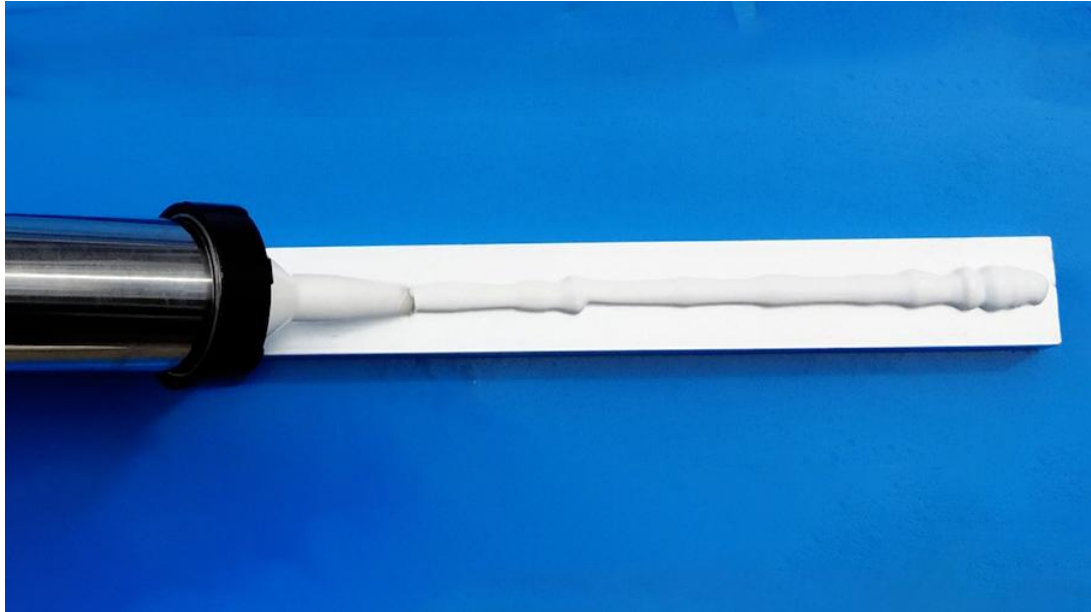

SMF430F-12X12UW
Aluminum tube layout

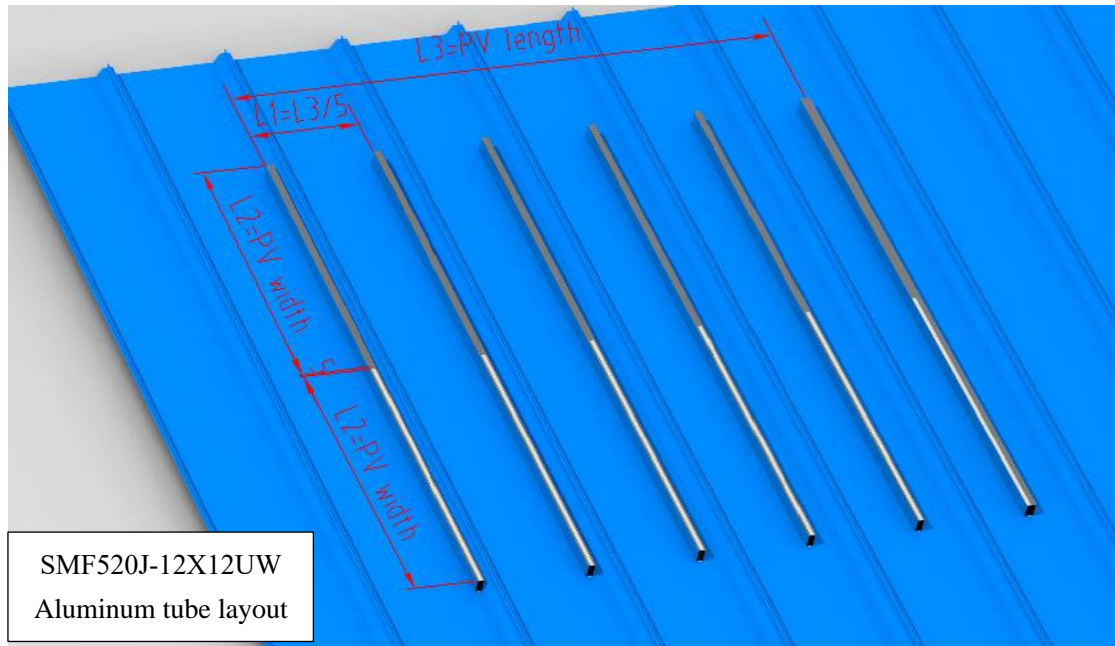

- If there are joints in the aluminum tube, they should be positioned between modules. Single module must not overlap the joints of the aluminum tube.

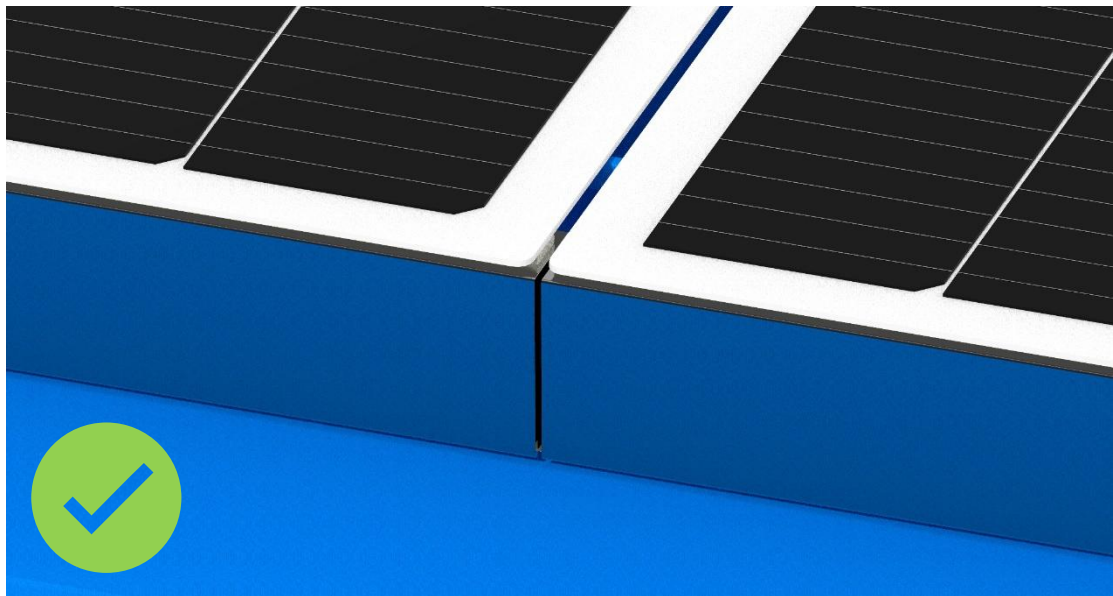

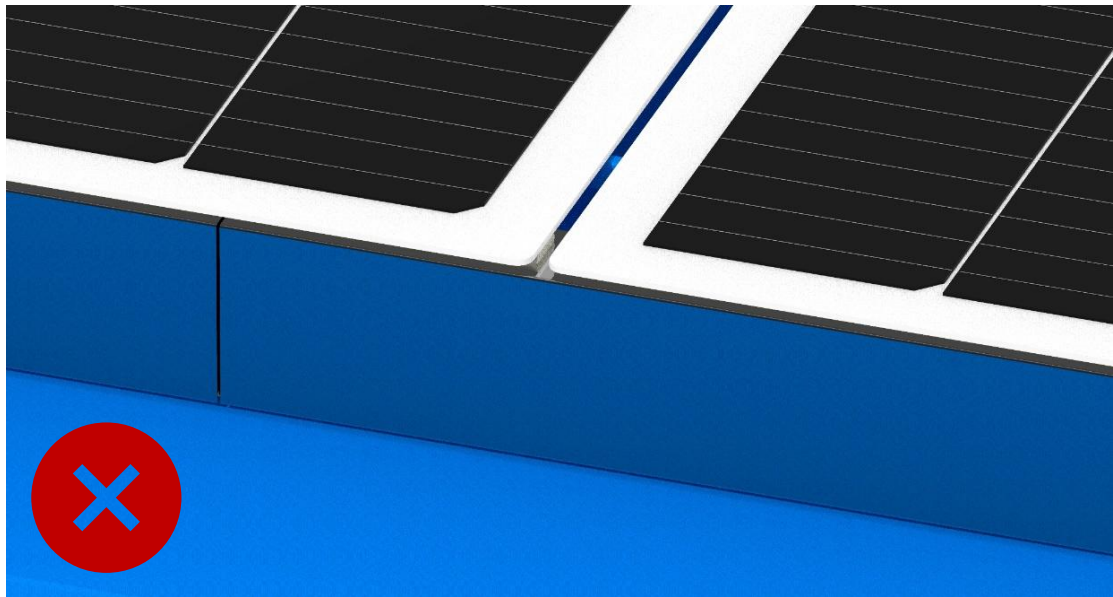

6.6.5 Laying modules

- Do not bend the module during installation. Two people should grasp the white edge of the module and place it onto the glue. Modules should be in a straight position during placement. Do not re-glue the modules.
- The short side of the module must be parallel to the aluminum tube. It is prohibited for the long side to be parallel to the aluminium tube.
- Once modules are placed, avoid hand-pressing the cell-area to facilitate adhesion.
- The minimum distance between the modules is 5mm, and the distance between each array is 500-800mm, which is used as a construction maintenance walkway. (This spacing is for reference only)
- Adjacent modules can share the same Aluminum tube
- Place the junction box on the maintenance walkway side for easy string wiring and maintenance inspection.
- Follow the steps above to install the other modules.

The following diagram shows SMF520J-12X12UW. Following this procedure, SMF430F-12X12UW can also be constructed in the same way.

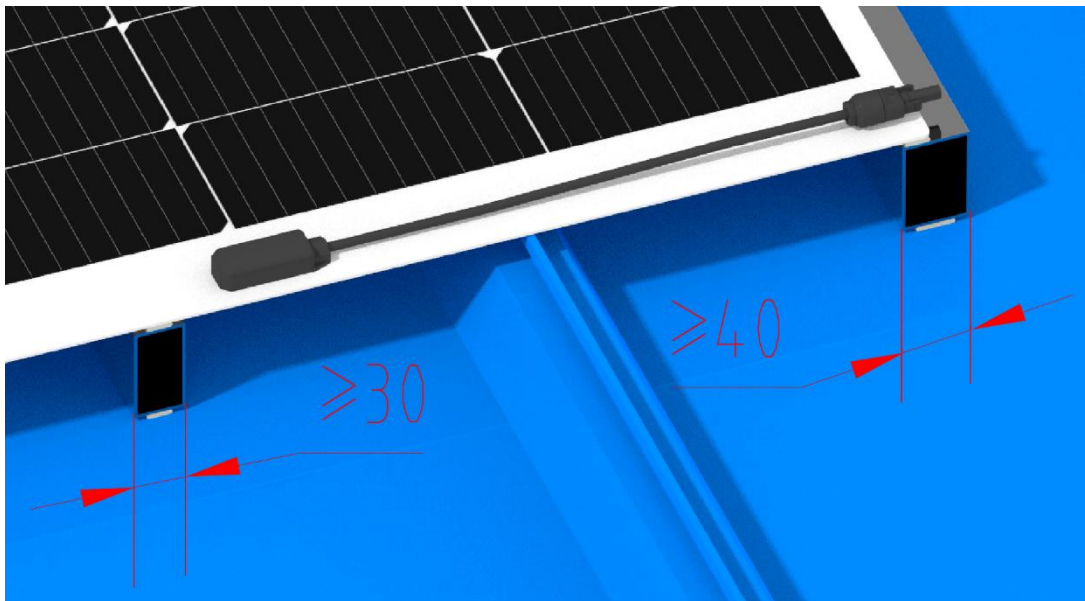
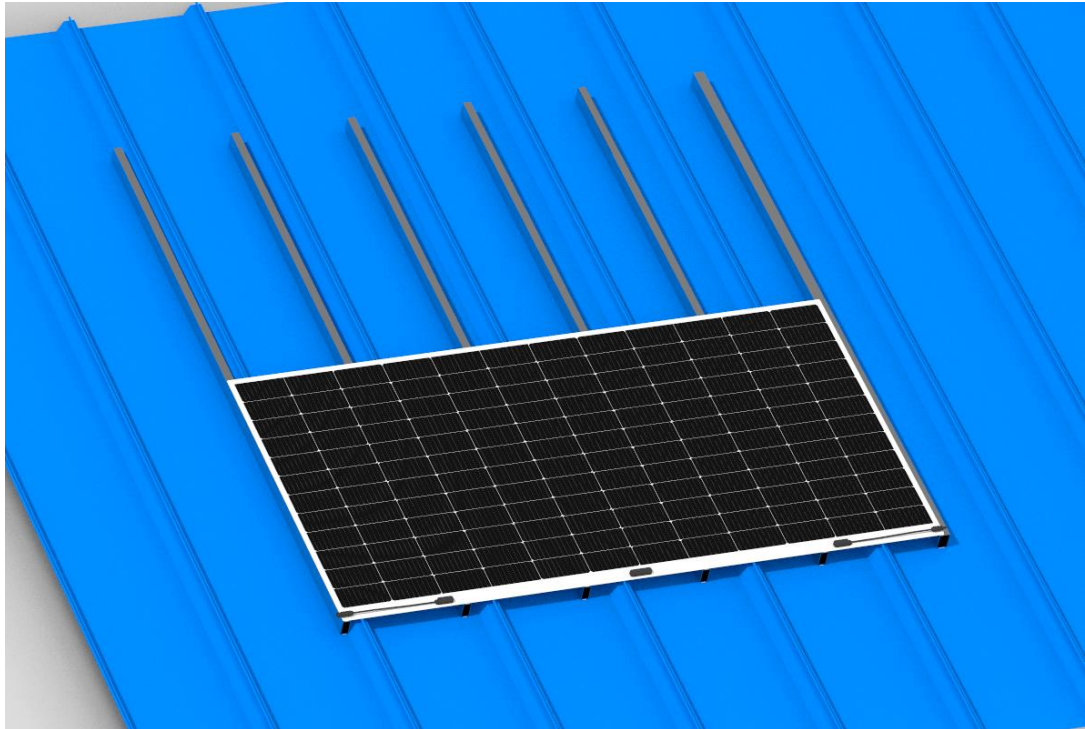

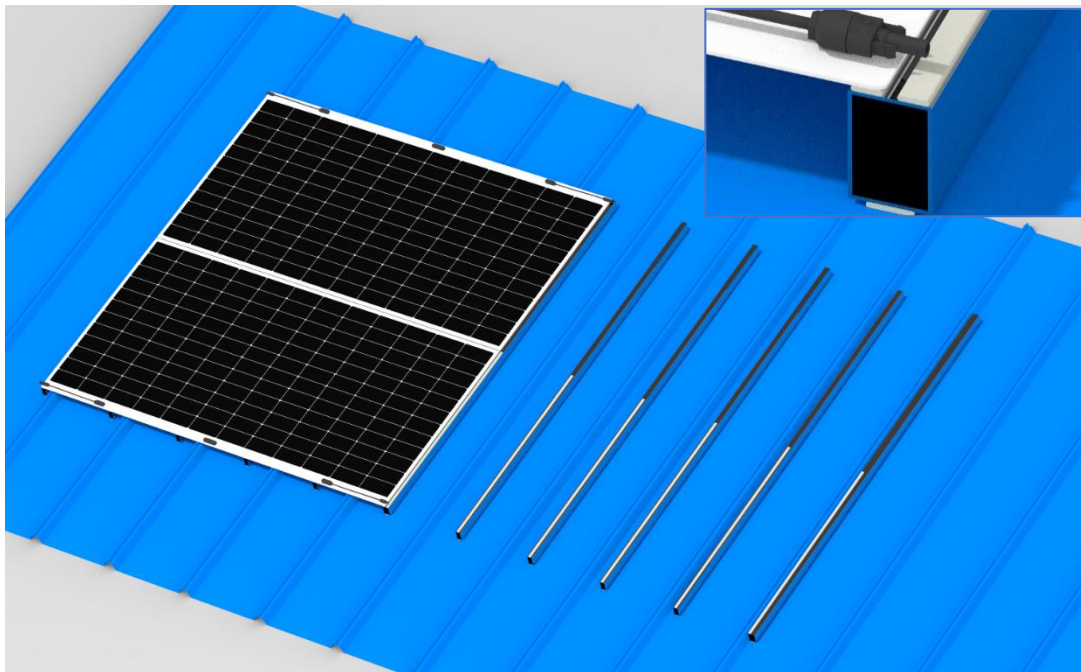
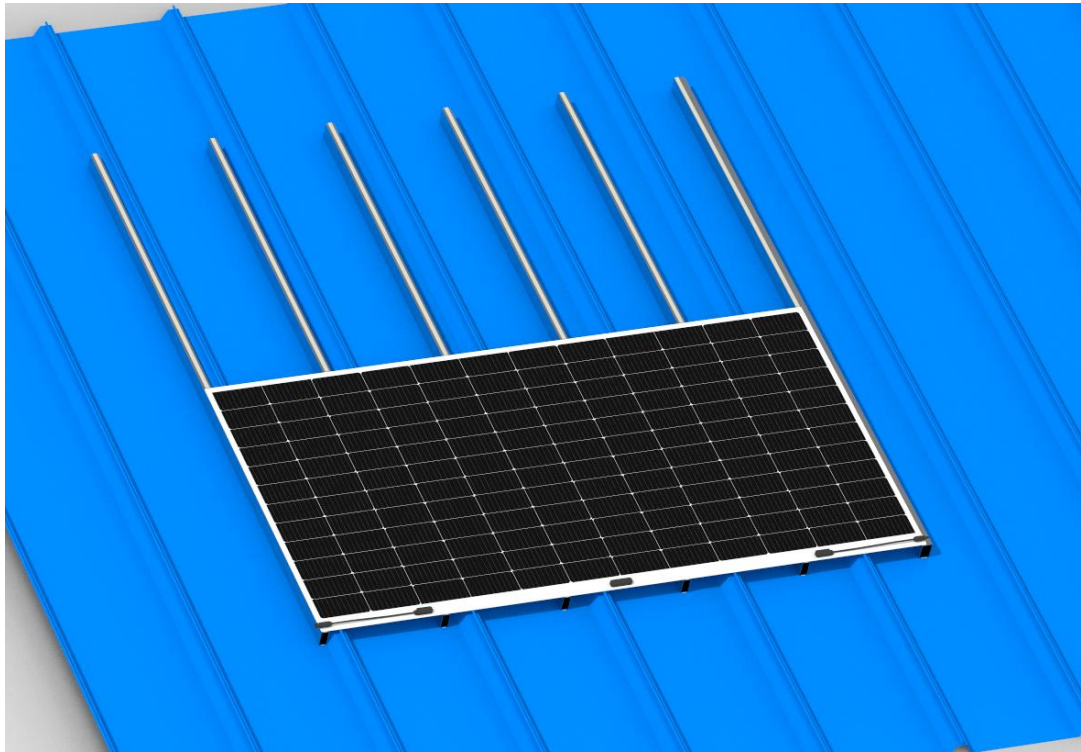

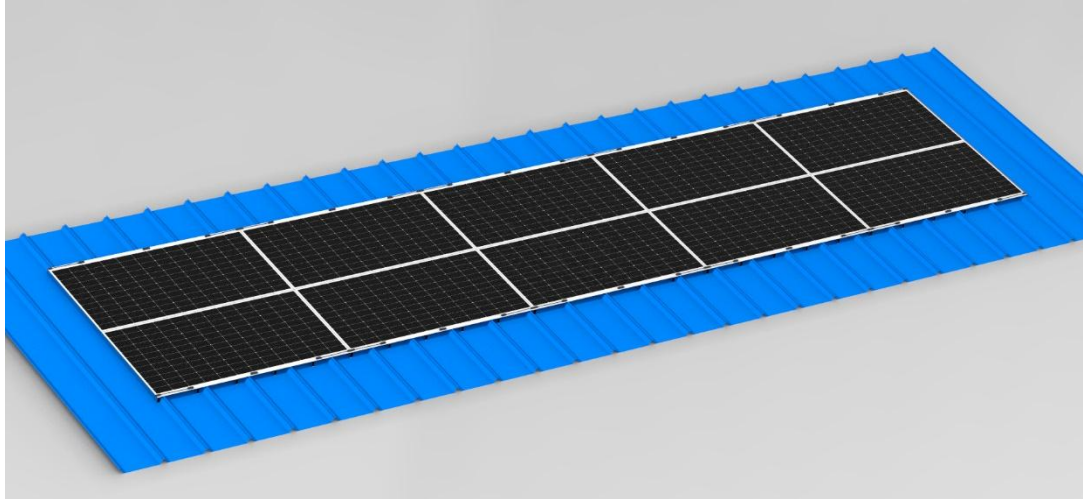

6.7 Flat Roof Aluminum Tube Construction Plan

Installation Steps

If the bitumen membrane surface has a protective film, the film must be removed before construction can proceed.

6.7.1 Supporting material

- Aluminum tube

The aluminum material should be 6000 Series-T5/T6. Minimum size recommended size will be as per the below

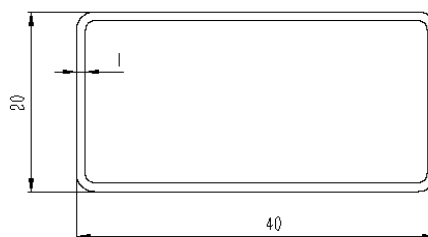

6.7.2 Cleaning the roof surface

Remove debris from the roof base and use a designated or approved cleaning agent (Annex B) to clean the roof. If the roof is very dirty, use a low-pressure water spray or power washer before using the cleaner. Optionally, use a mixture of 1/4 cup of trisodium phosphate, 1/2 cup of liquid cleaner and 5 gallons of water for cleaning.

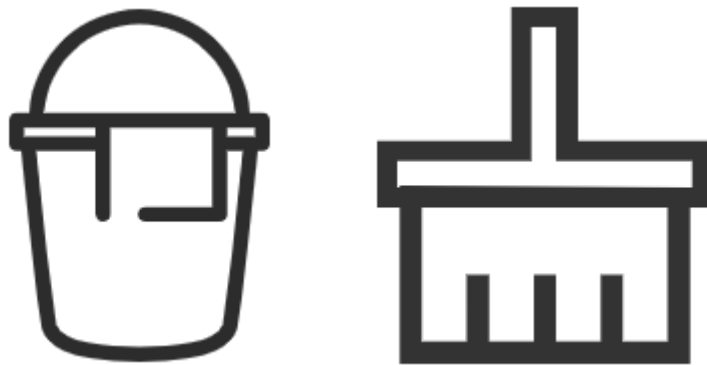

6.7.3 Positioning

- Positioning and securing lines to determine the spacing of aluminum tubes or PVC tubes in accordance with the design drawings (For design drawings, please contact SunMan).



- For the SMF430F-12X12UW, at least five aluminum tubes or PVC tubes are used to support the module, and are evenly distributed in the length direction of the module.
- For the SMF520J-12X12UW, at least six aluminum tubes or PVC tubes are used to support the module, and are evenly distributed in the length direction of the module.

6.7.4 Apply primer (ignore this step if no primer required for the roof material)

- Determine the gluing area of the modules after the roof cleaning (refer to the design drawing for specific dimensions);

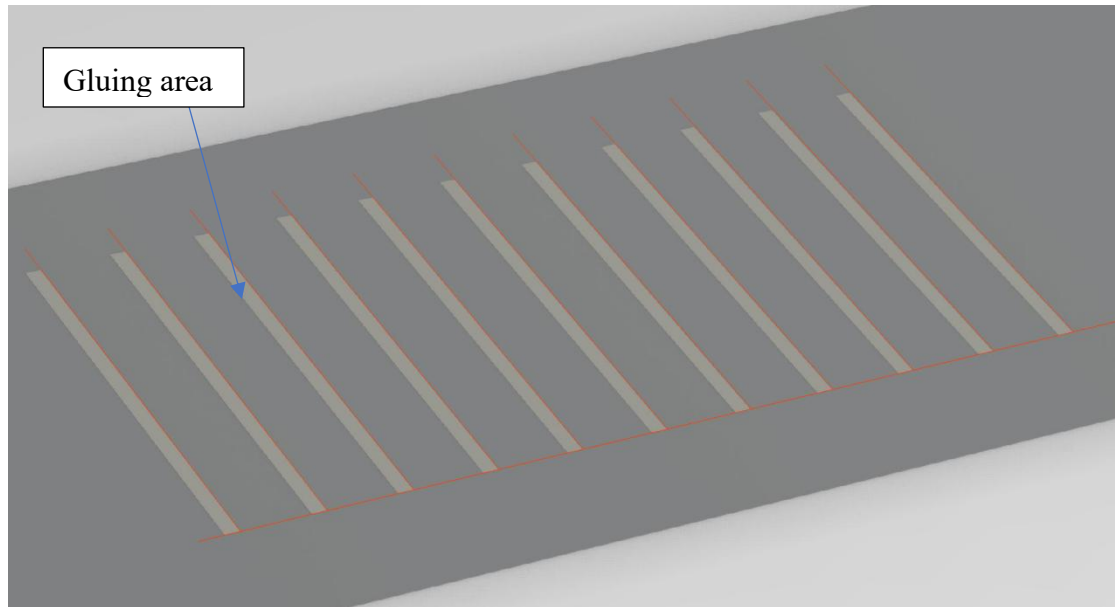

- Clean the gluing area again, wipe the area with the cleaning agent in Annex B;
- For the gluing area, apply primer before gluing.

6.7.5 Apply activator for PVC tube (ignore this step for the aluminum tube)

- Before commencing construction, please ensure you have read the activator manufacturer's manual to ensure that all the activator application requirements are followed.
- After 5 minutes of activator application when the activator has dried, continue with the installation of the glue. The glue needs to be completed within 2 hours of the application of the activator. If more than 2 hours have passed after the application of the activator, it will need to be reapplied (The specific available period of activator is subject to the information of the activator manufacturer).

6.7.6 Paste tube

- Glue the silicone sealant continuously and uniformly in the glue area. It is strictly prohibited to apply adhesive in a dotted or segmented manner.

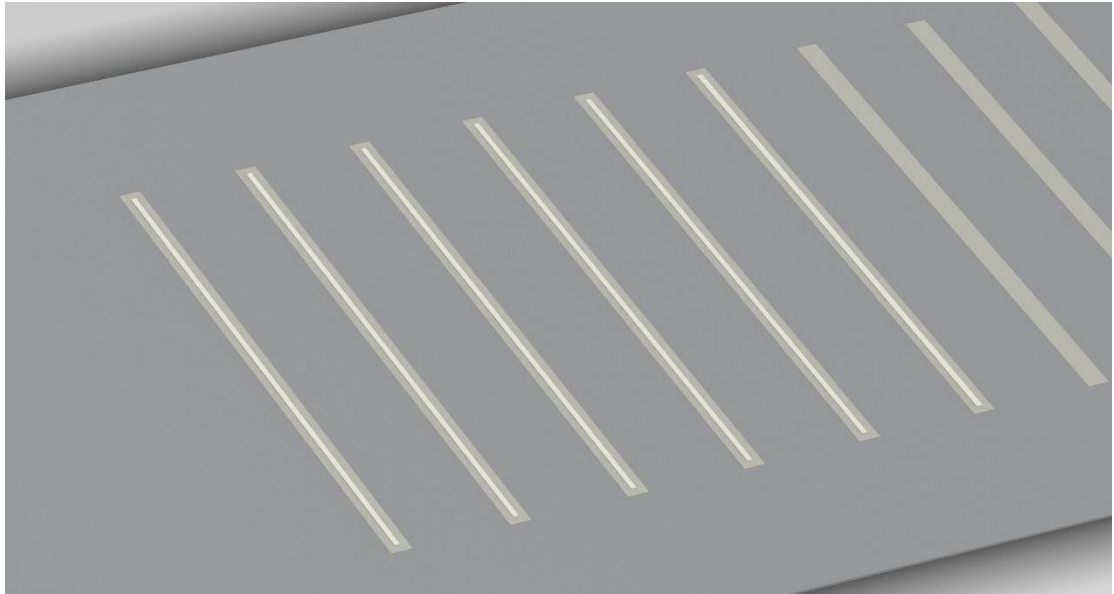

- Paste the tube along the gluing path and lightly compress. Ensure the bead height is not less than 3mm

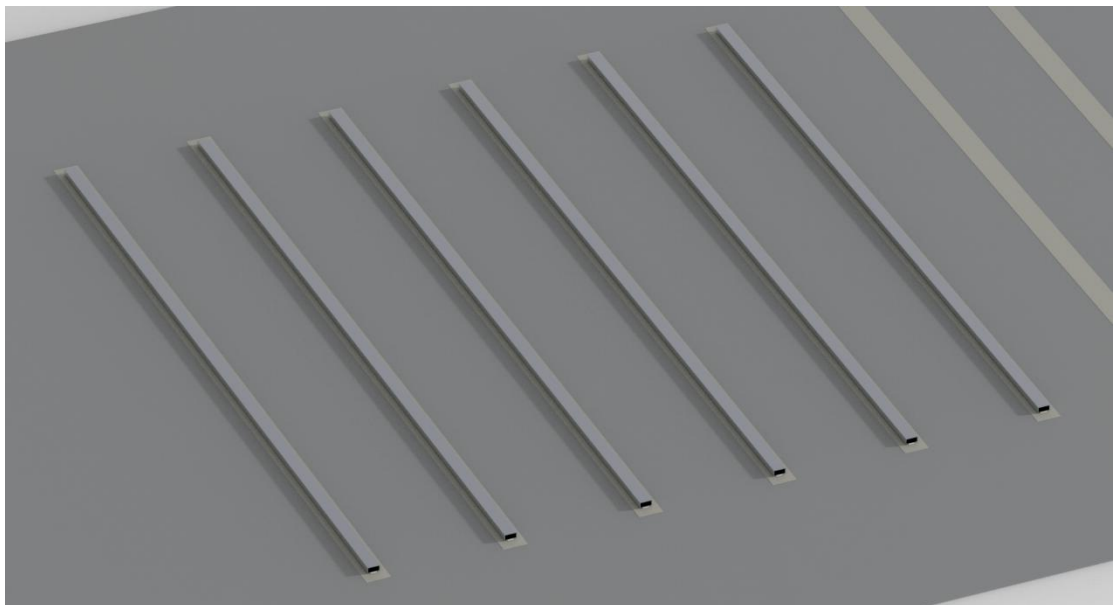

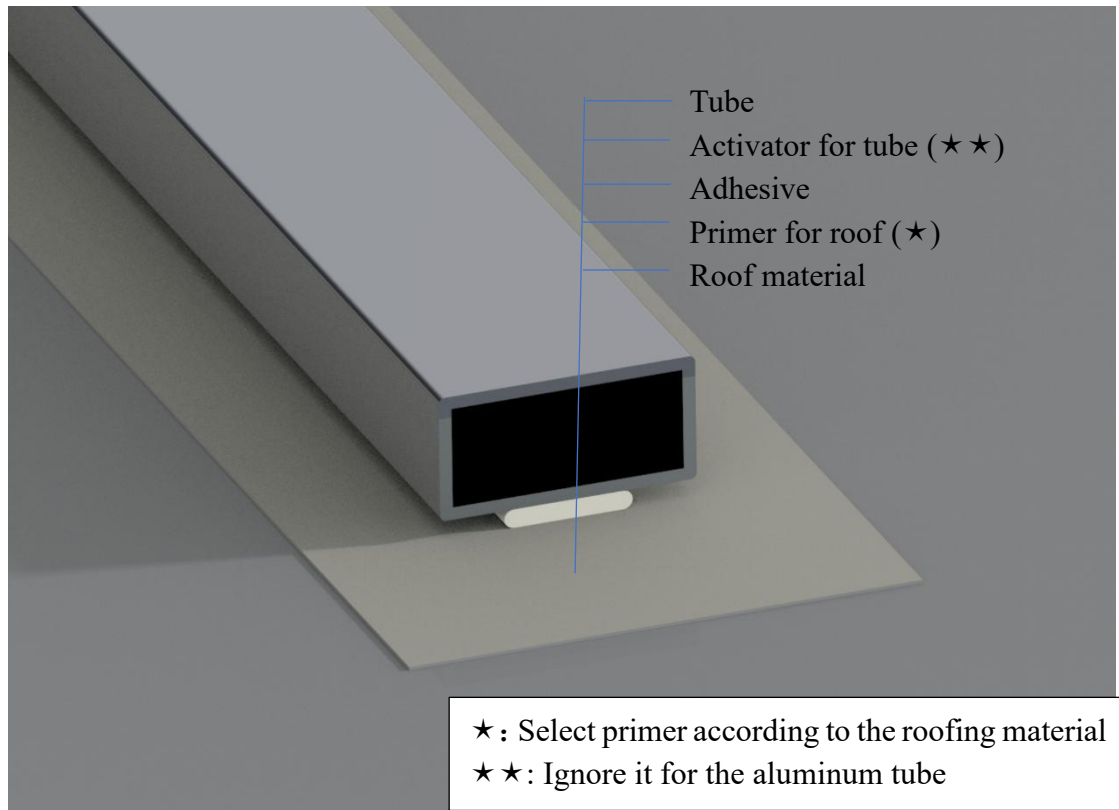

6.7.7 Laying modules

- Making Glue continuously and uniformly on the tube followed the Precautions and Tips for Gluing Modules. It is strictly prohibited to apply adhesive in a dotted or segmented manner.



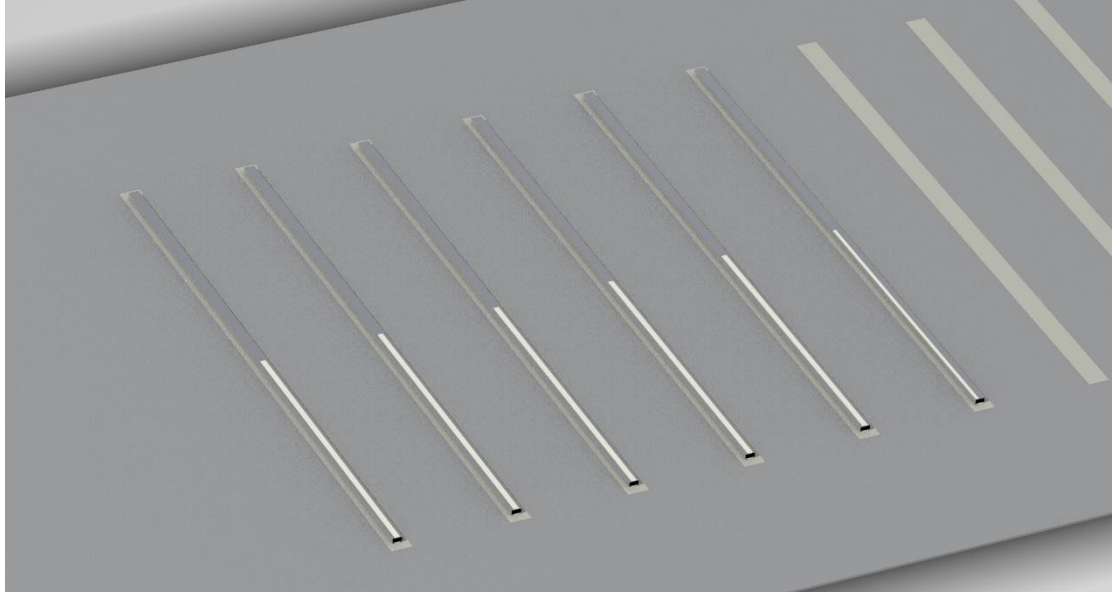

- Do not bend the module during installation. Two people should grasp the white edge of the module and place it onto the glue. Modules should be in a straight position during placement. Do not re-glue the modules.
- The short edges of the module must be parallel to the aluminum tube or PVC tube. It is prohibited to be perpendicular to the aluminum tube or PVC tube.
- Once modules are placed, avoid hand-pressing the cell-area to facilitate adhesion.
- The minimum distance between the modules is 5mm, and the distance between each array is 500-800mm, which is used as a construction maintenance walkway. (This spacing is for reference only)
- Place the junction box on the maintenance walkway side for easy string wiring and maintenance inspection.
- Follow the steps above to install the other modules.

The following diagram shows SMF520J-12X12UW. Following this procedure, SMF430F-12X12UW can also be constructed in the same way.

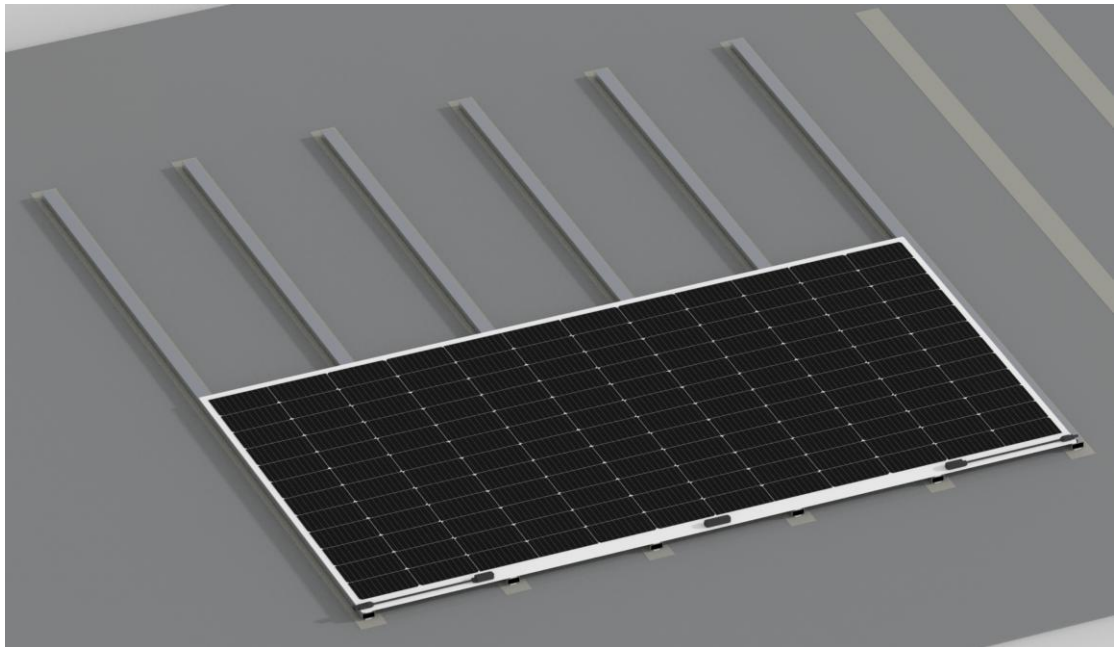
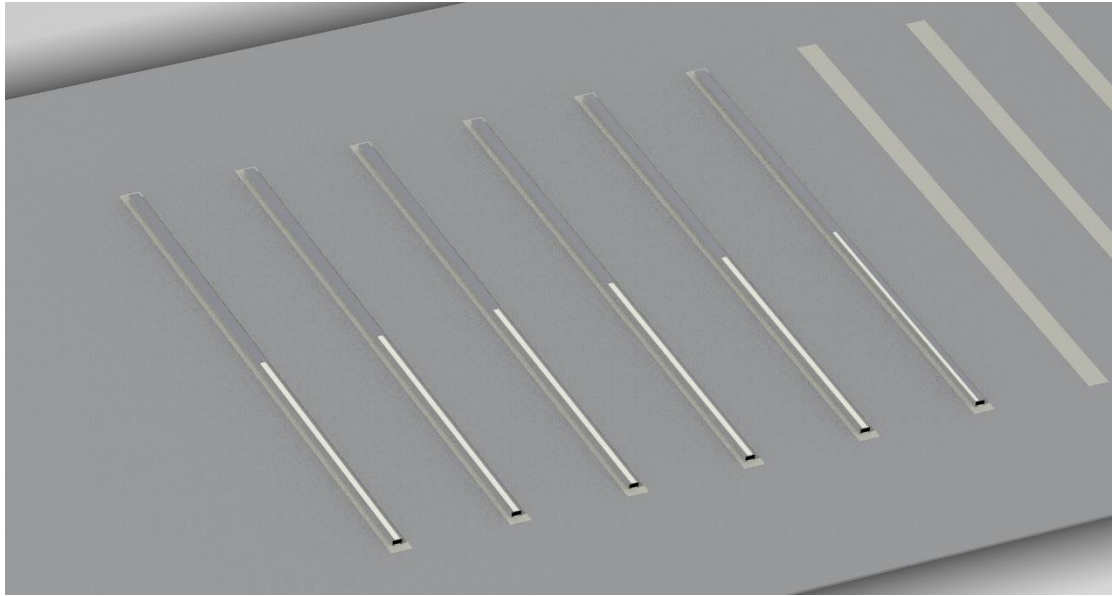

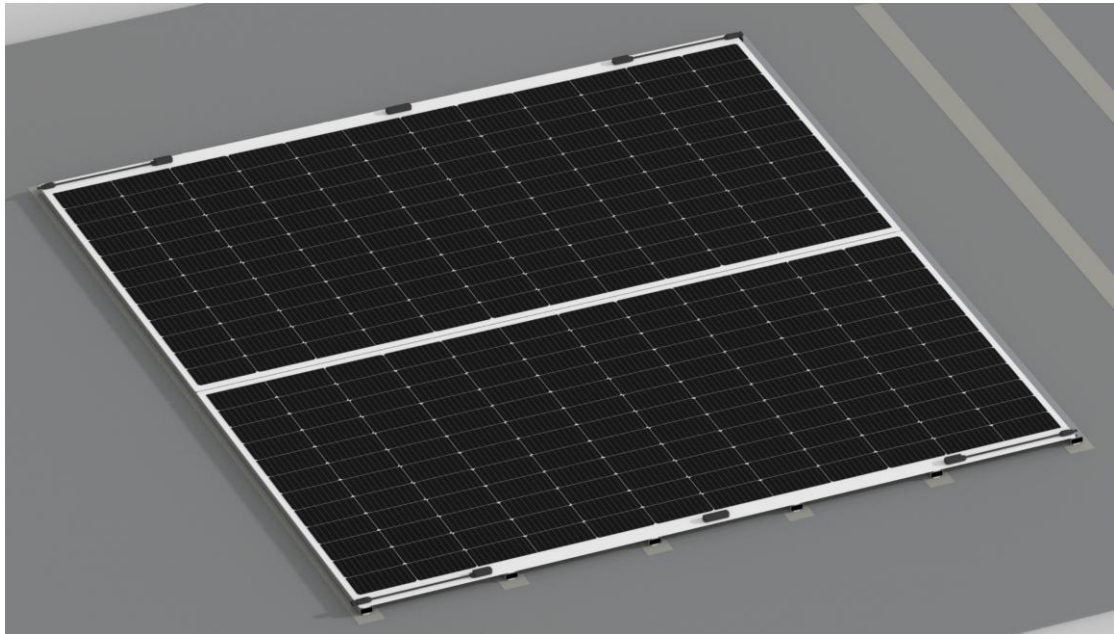
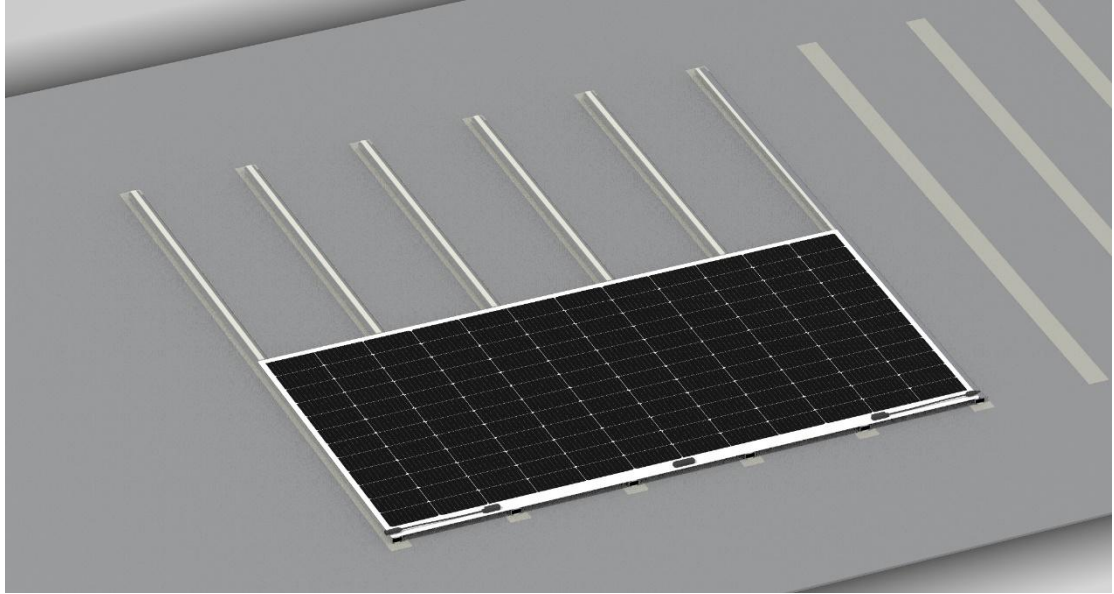

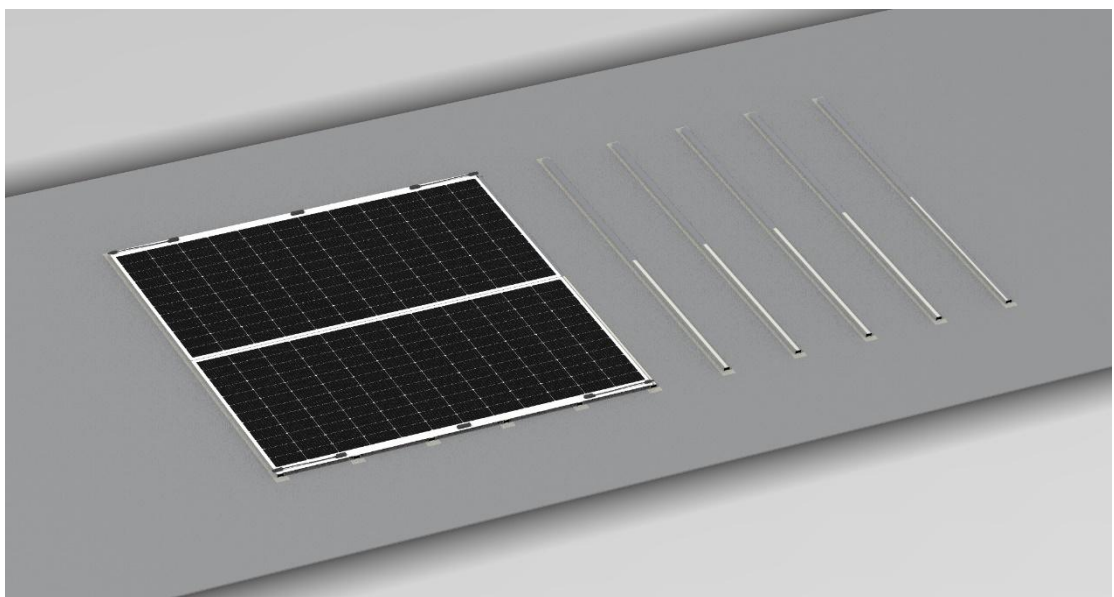
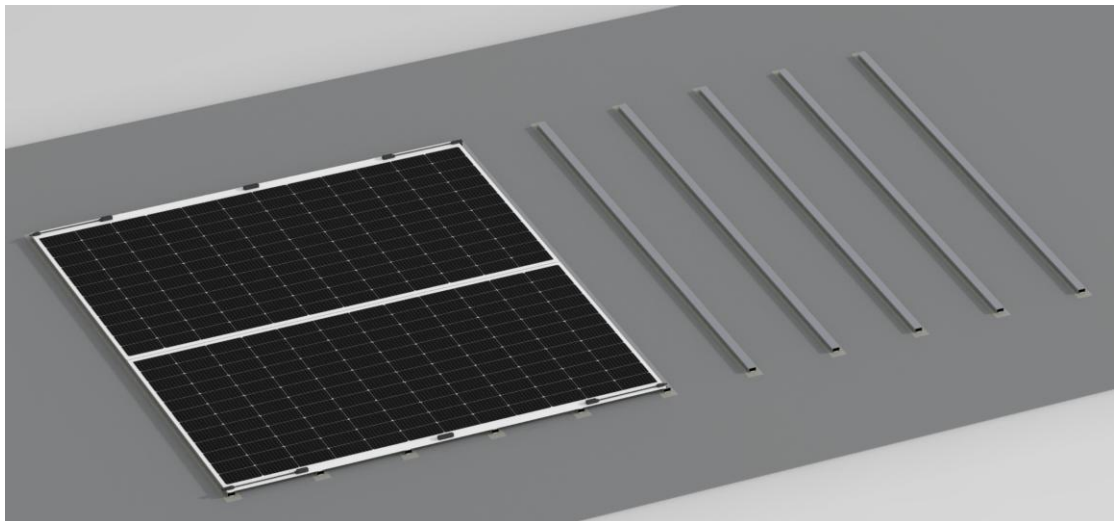
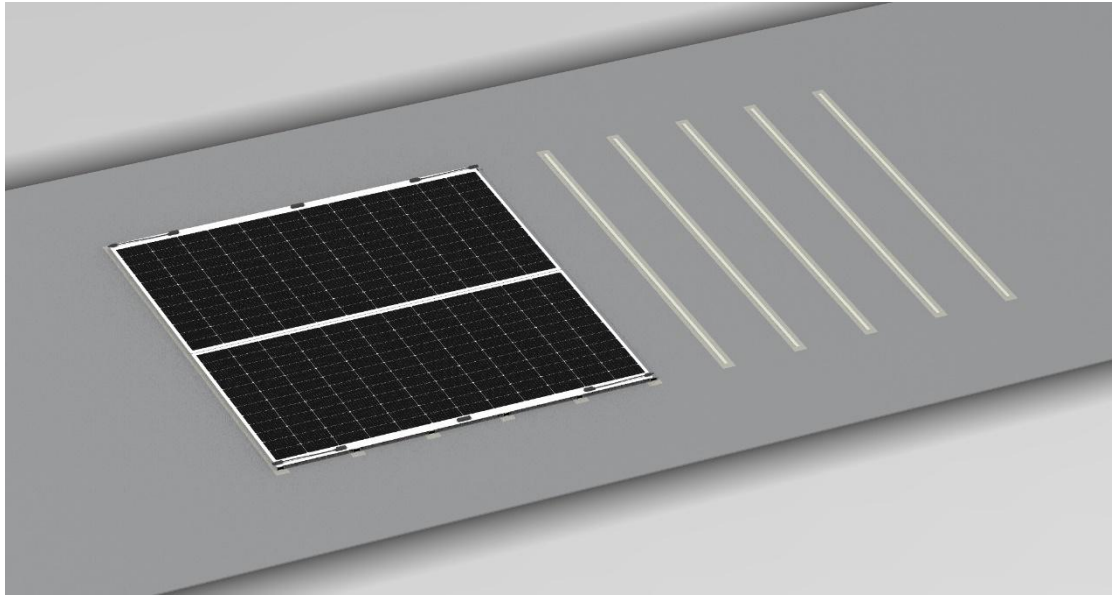

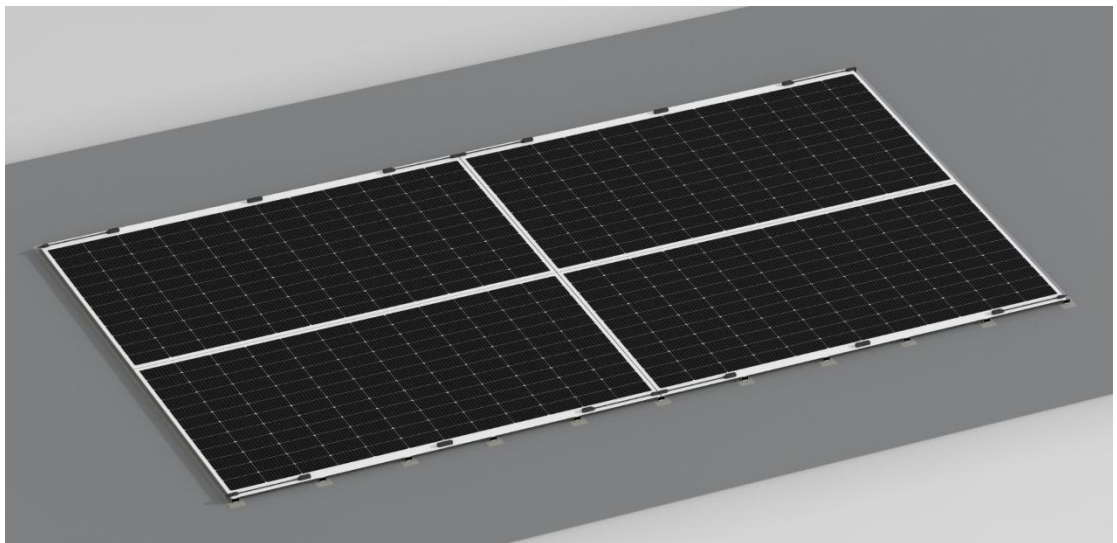
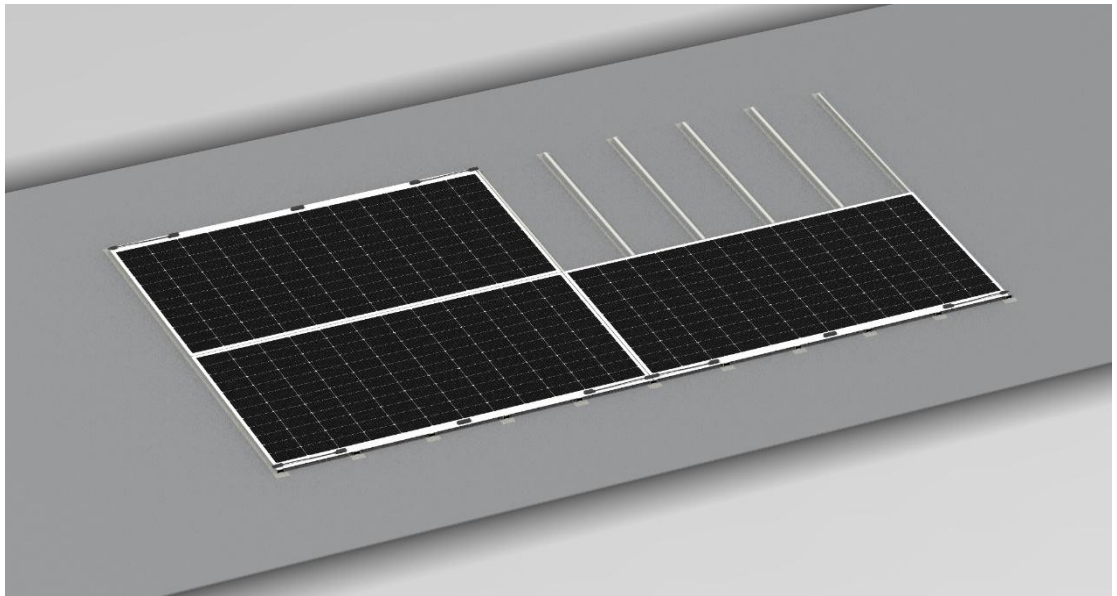
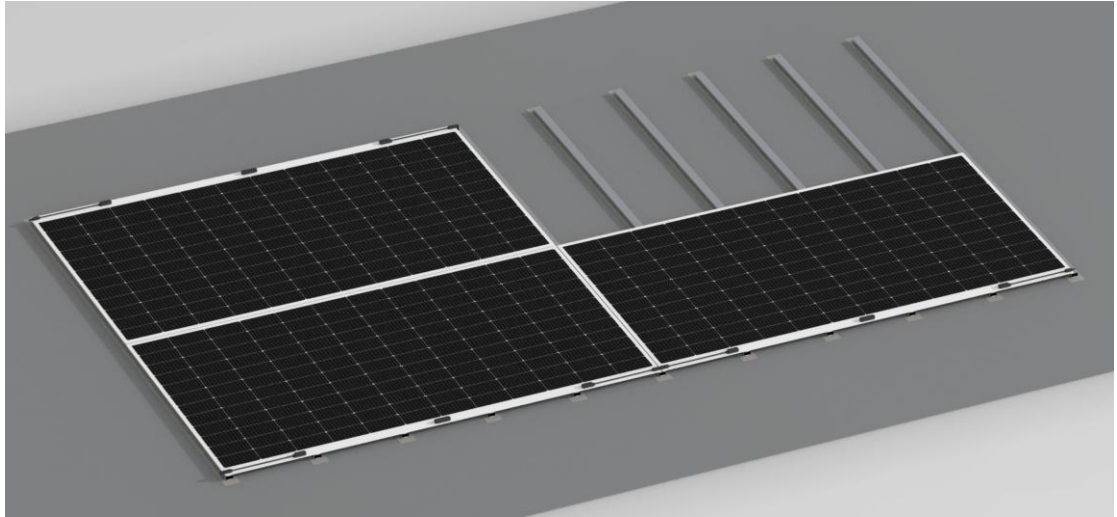

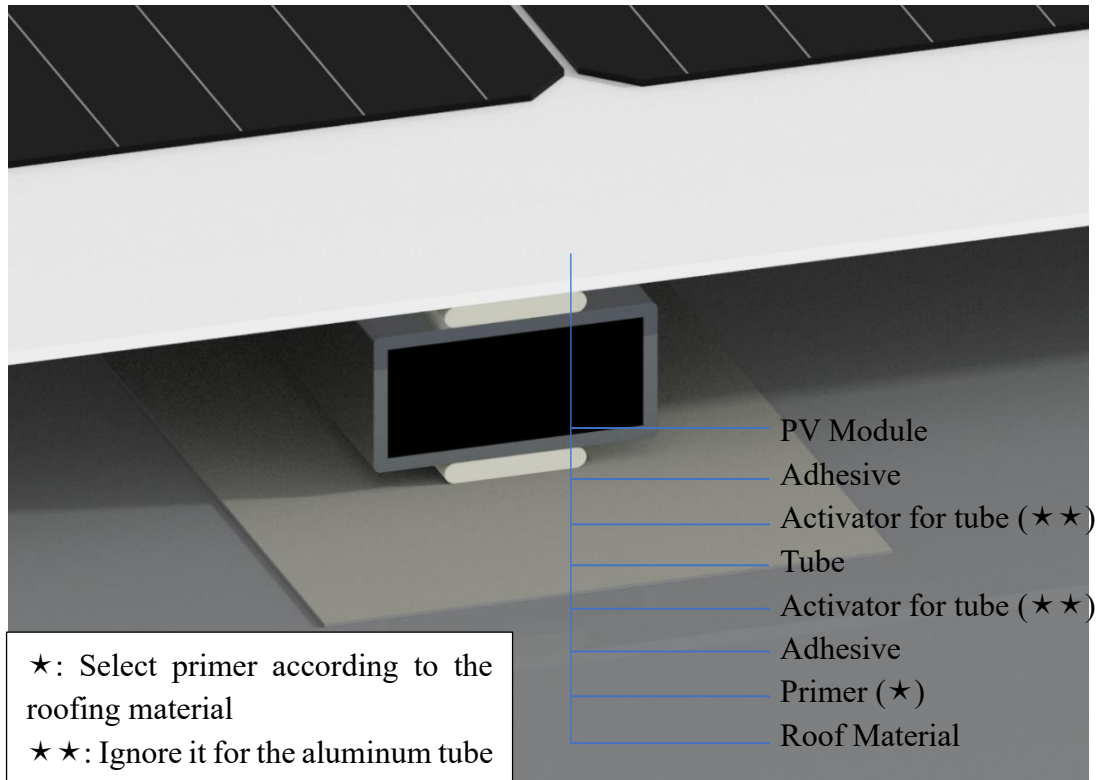

6.7.8 Joint of tubes

- If there are joints in the aluminum tube or PVC tube, they should be positioned between modules. Single module must not overlap the joints of the aluminum tube or PVC tube.

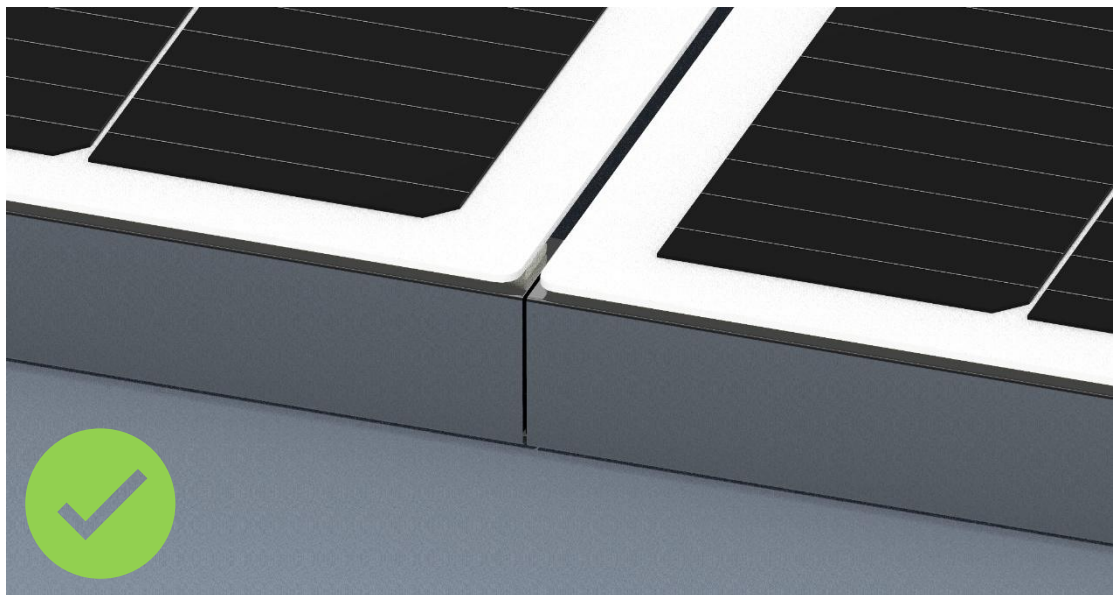

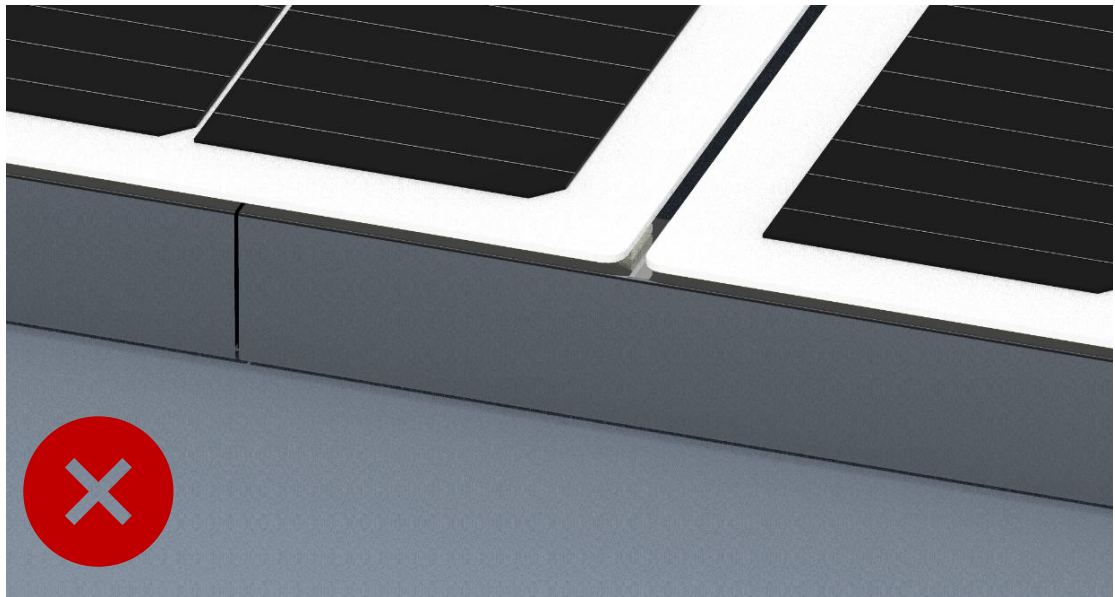

6.8 Mechanical load

Installation method Module type	Trapezoidal Metal Roof Plan	Standing Seam Metal Roof Plan	Flat Roof Aluminum Tube Plan
SMF430F-12X12UW	+5400 /-2400Pa	+5400 /-2400Pa	+5400 /-2400Pa
SMF520J-12X12UW	+5400 /-2400Pa	+5400 /-2400Pa	+5400 /-2400Pa

6.9 Wiring and testing

- The use of PV modules with different electrical characteristics in a PV system is prohibited.
- Excessive cables must be organized or fixed in the proper location, do not cover the cell area.
- For applications requiring high operating voltages, several PV modules may be connected in series to form a PV string, then the system voltage is equal to the sum of the voltages of each PV module
- For applications requiring high operating currents, several strings of PV modules can be connected in parallel to form a PV string, then the system current is equal to the sum of the currents of each PV module string.

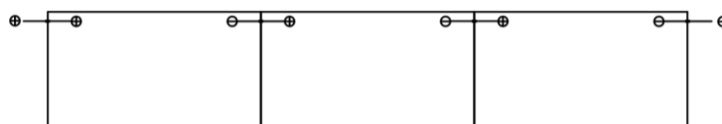

Series connection

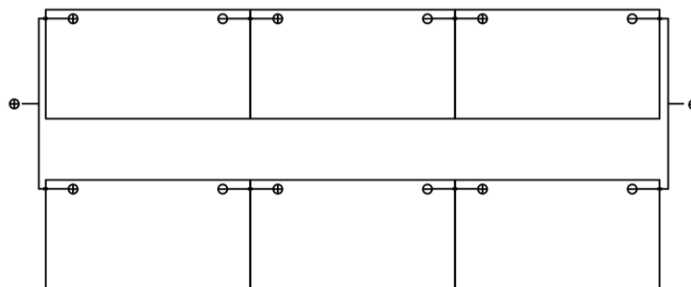

Parallel connection

- A maximum system voltage of 1500VDC is allowed.

- The maximum number of PV modules in series depends on the system design, the type of inverter used and the environmental conditions.
- Depending on the maximum series fuse rating of the PV module and local electrical installation codes, if the PV module does not have any fuses or blocking diodes, make sure to connect no more than two strings in parallel.
- There is no limit to the number of PV modules that can be connected in parallel (fuses per string should be considered), the number of PV modules is determined by system design parameters such as current or power output.
- Please refer to local regulations to determine the size, type and temperature of the system conductors.
- PV modules are equipped with connectors for system electrical connections, please refer to local regulations and data sheets that allow the use of connectors.
- To ensure a reliable electrical connection and to prevent possible moisture ingress, connectors must fit and lock together until a click is heard.

The DC power generated by the PV system can be converted to AC power and connected to the public grid, as the local power company's policy for connecting renewable energy systems to the grid varies from region to region. You can ask your PV system design engineer or integrator for help in obtaining building permits, inspections, and approvals from your local power company's department.

7.0 Maintenance

To ensure optimal performance of modules and maximize system power generation, the following maintenance measures are recommended:

1. Module appearance inspection, focusing on the following points:
 - a) Whether the module is damaged.
 - b) Whether there is a sharp object touching the surface of the module.
 - c) Whether the modules are obstructed by obstacles and objects, avoiding new trees, new poles etc. to shielding the modules.
 - d) Check for corrosion near the busbar. This kind of corrosion is caused by the damage of the module surface during transportation, which causes moisture to penetrate into the interior of the module.
2. Clean the modules. The accumulation of dust or dirt on the surface of the modules will reduce the power output. It should be cleaned regularly to keep the surface clean. Generally, it should be cleaned at least once a month, appropriately increase the frequency in the harsh natural environment. Pay attention when cleaning PV modules:
 - a) Rinse with water first, then dry the water with a soft cloth. Do not use corrosive solvents to clean or wipe the PV modules with hard objects.
 - b) The PV module should be cleaned at an irradiance of less than 200 W/m^2 . It should be cleaned in the absence of sunlight or in the morning and evening.
 - c) It is strictly forbidden to clean PV modules under meteorological conditions where the wind is greater than grade 4, heavy rain or heavy snow.

Note: Do not walk, stand or sit on the module when cleaning.

3. Connector and cable inspection. It is recommended to conduct a preventive inspection every six months:
 - a) Check for signs of aging of PV modules, including possible rodent damage, weathering, and whether all connectors are tightly connected or corroded.

Annex A

Electrical performance parameter

Series	Products	STC					Module size
		Pmp	Vmp	Imp	Voc	Isc	
	SMF430F-12X12UW	430	42.00	10.74	49.80	10.74	2054*1084*2
	SMF520J-12X12UW	520	42.26	12.31	49.54	13.56	2246*1197*2

Annex B

Cleaning agent

Roof type	Cleaning agent recommended by SunMan
TPO, PVC, Asphalt, EPDM, etc. plastic roof	Plastic cleaner China: RA-1033 Overseas: Use the cleaning agent recommended by the roofing material supplier
Color metal tile, glass roof, metal roof	90% isopropanol + 10% water

Use the cleaners listed above or those recommended by the roofing material supplier.



Annex C

Gluing operation specification

1. Gluing nozzle cutting

The standard nozzle cutout is 10.5mm x 6mm, which is made by cutting about 20mm from the original nozzle and flattening it to the required size, as shown in the figure below.

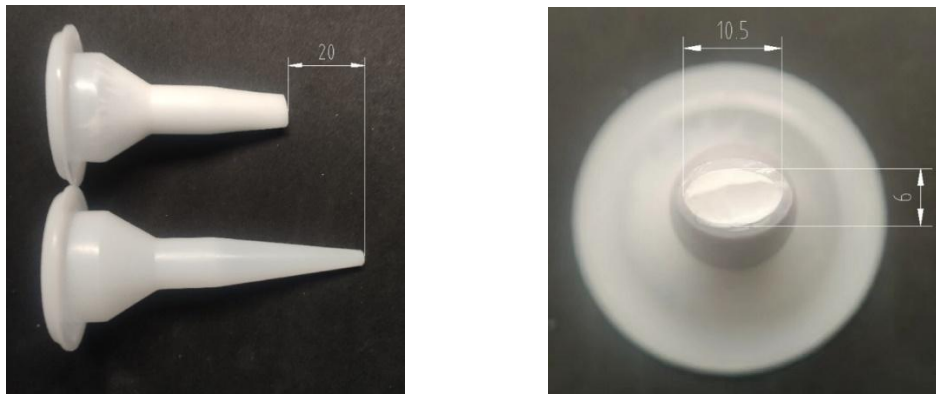

Nozzle cutting should be carried out in strict accordance with the following procedures.



Standard tool shears (complimentary with adhesive)

Operation steps

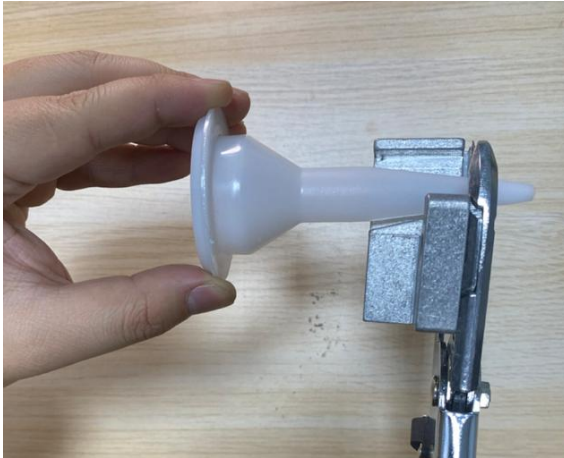

1. Use a straightedge or tape measure to measure the length of the head of the nozzle 20mm, confirm the cutting position, and then use the tool to cut in addition.



2. It is recommended to use a lighter to heat the tip of the rubber nozzle for about 2s to prevent it from springing back after being flattened.

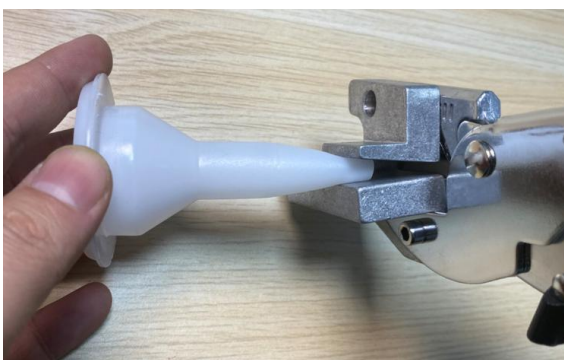

3. Squeezing of the nozzle to the desired size using a flattening die of the tool shears.

2. Electric glue gun adjustment

Standard glue-out speed: Half turn of the speed knob, see the following figure:

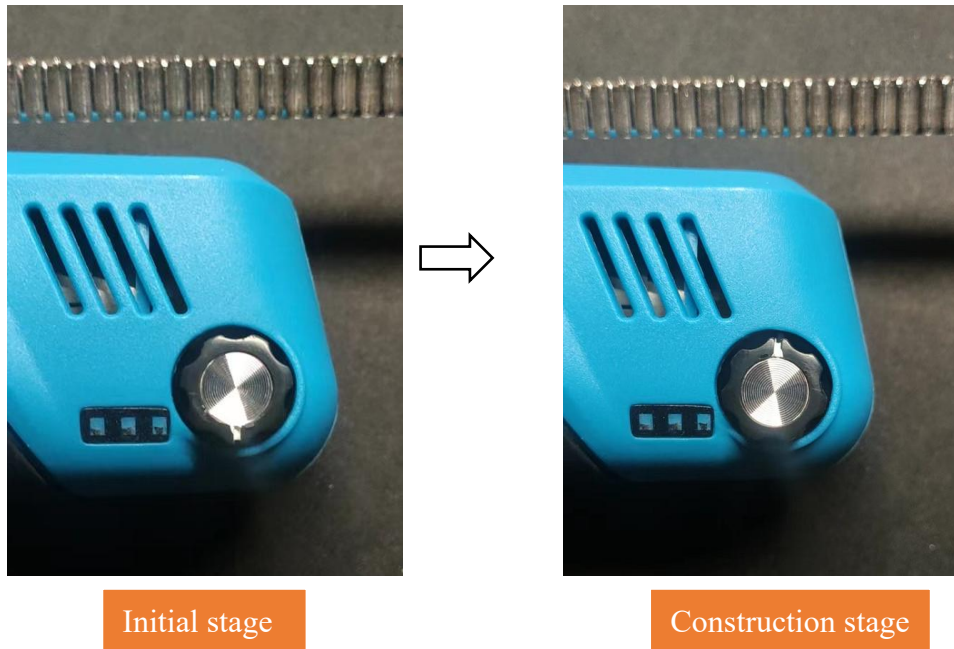

3. Gluing parameters

Gluing length: 10.8m/600ml on average

Gluing speed: about 10cm/s



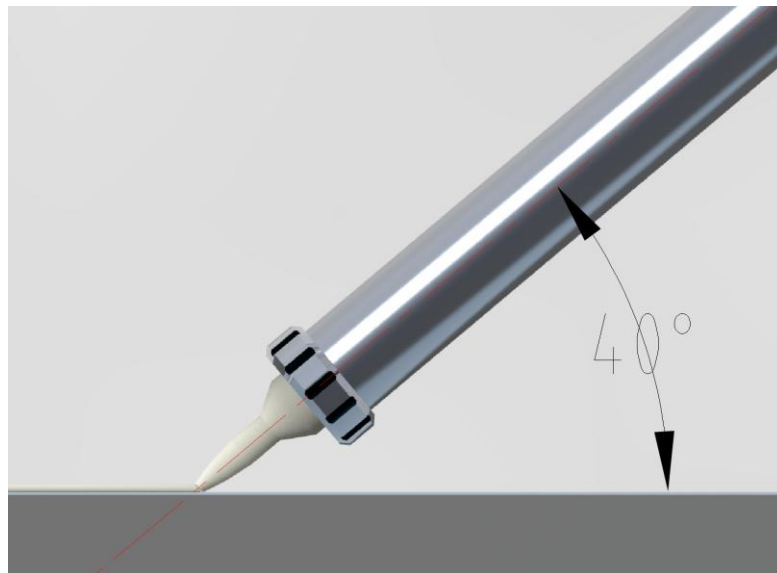





Gluing angle: the glue gun is at an angle of about 40° with the ground, as shown in the following figure:

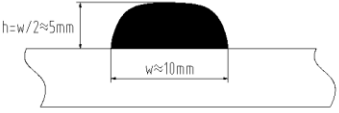







Adhesive size and standard dosage: at least 10*5mm; 5 strips/1 module (adhesive along the width of the PV module); 3 strips/1 module (adhesive along the length of the PV module)

4. Structural adhesive form

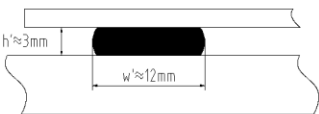
Please see below for proper bead application

	
 Correct dimension	 Too flat
	
 Too high, too small	 Poor wetting

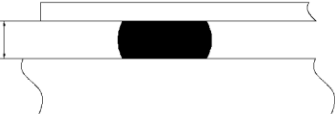
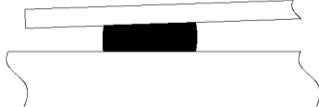
The correct form of structural adhesive after pasting modules

	
 Correct dimension	 Too flat
	
 Too high	 Inclined

(The specification is subject to the information of the glue manufacturer)

Annex D

Unpacking

Standard unpacking steps for light weight PV modules.



1. Remove all wrapping film and packing tape outside the package



2. Remove packing box cover (keep well for another purpose)

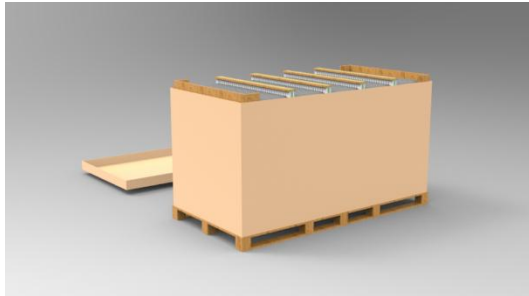

3. Place the cover next to the box with the opening up



4. Remove the outer packaging carton



4.1. Box cover retention (handling module auxiliary parts)



5、 Remove the upper fence on the side of the wooden box, keep the lower fence



6. Use scissors or a hobby knife to cut off the packing tape used to secure the module (do not cut the module)



7. Remove the fixing clip above the module

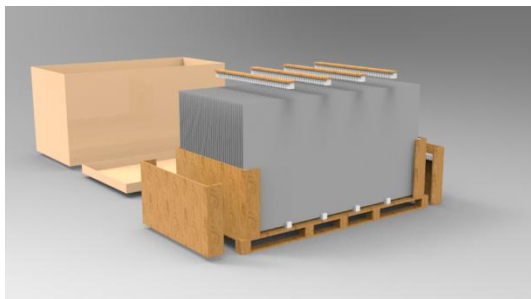
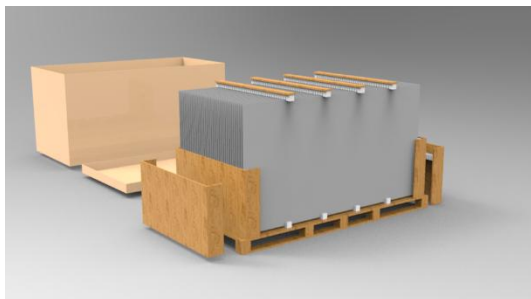

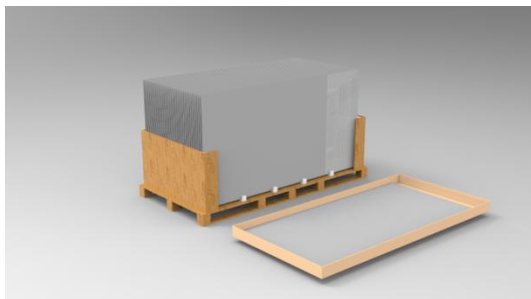
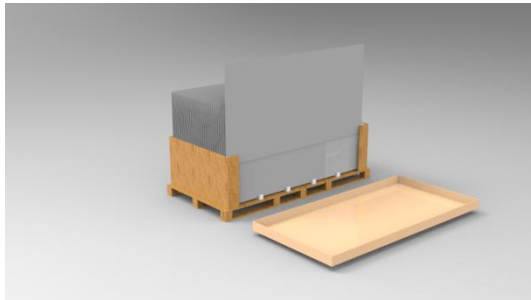
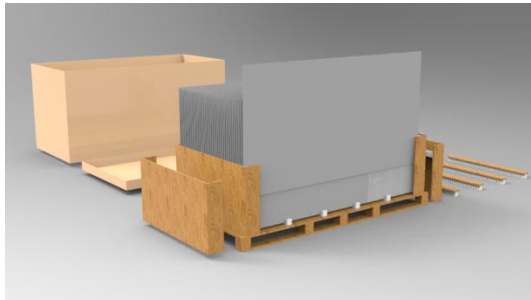
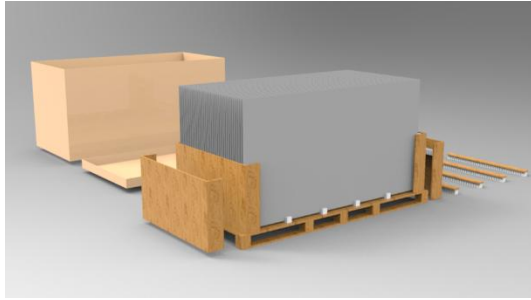

8、 To pick up the module, please raise the module to the height of the lower C-shaped enclosure and move out the module

When picking up the module, please grab the non-cell white area of the module.

When picking up the module, grab the long side direction of the module, the short side direction of the module can only be short grabbed again when out of the box operation

9、 Place the box cover open side up and transport the module flat inside the cover to the project designated installation site
Place a maximum of two modules in the cover, separated from each other with foam inside the box

Use a minimum of four foam strands, placed evenly between the stacked modules.

Module stacking and handling operations are as follows:

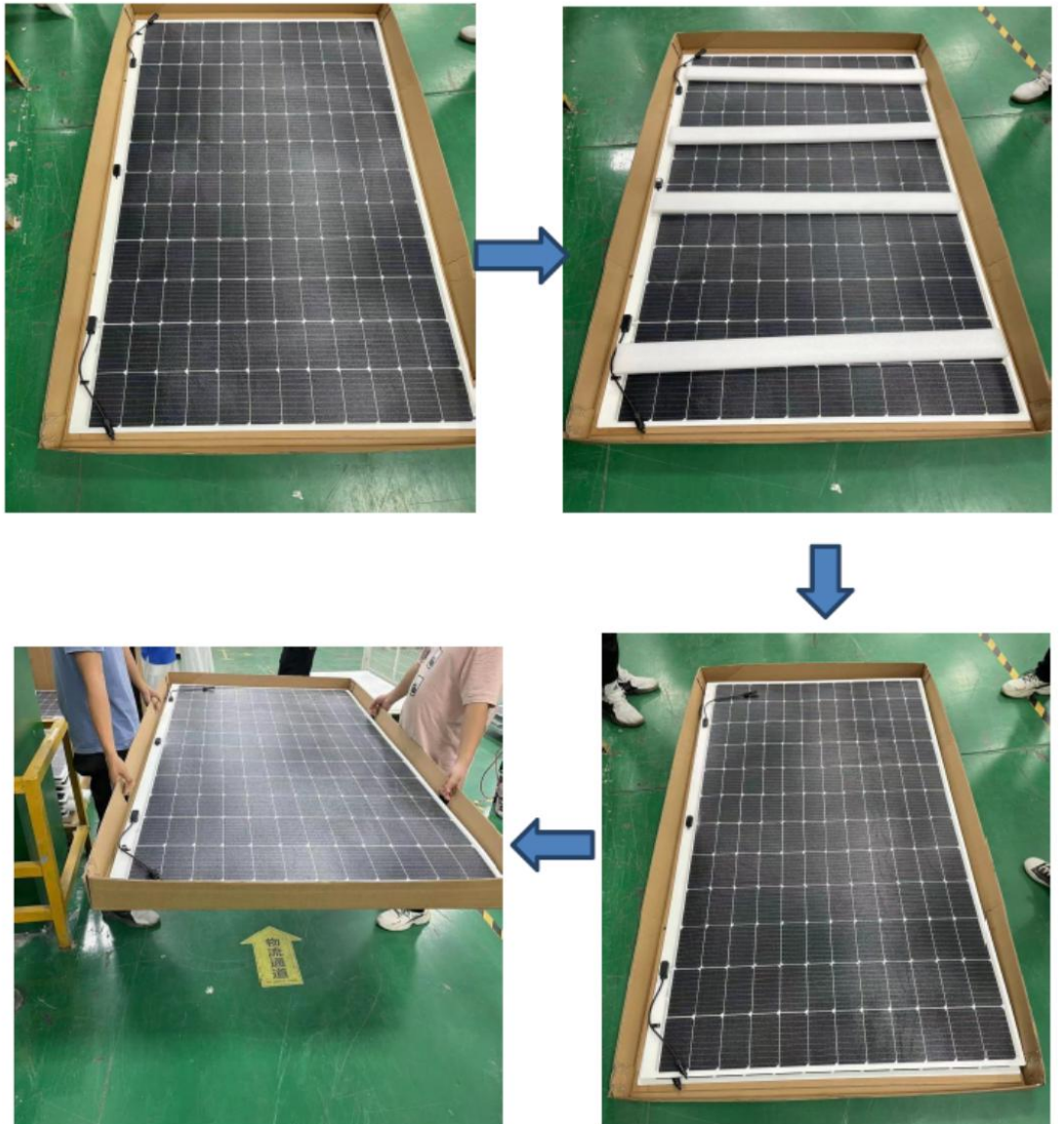

Unpacking precautions

Avoid operating in rainy weather when opening cartons outdoors.

Secure the modules when operating outdoors in windy conditions.

Stack modules in a ventilated, rain-proof, and dry area before unpacking them.

Do not to damage the front or back of the module when using scissors or hobby knife to cut the outer packing tape.

Confirm the number of modules in the box promptly after unpacking.

The unpacking area needs to ensure that the box is placed horizontally and stably to avoid tipping of the modules.

During unpacking and handling, please wear protective gloves properly to avoid scratches.

Prohibit pulling on junction boxes or cables under any circumstances.

When handle the modules, avoid touching the cell area with hands.